

CONCRETE STRUCTURES

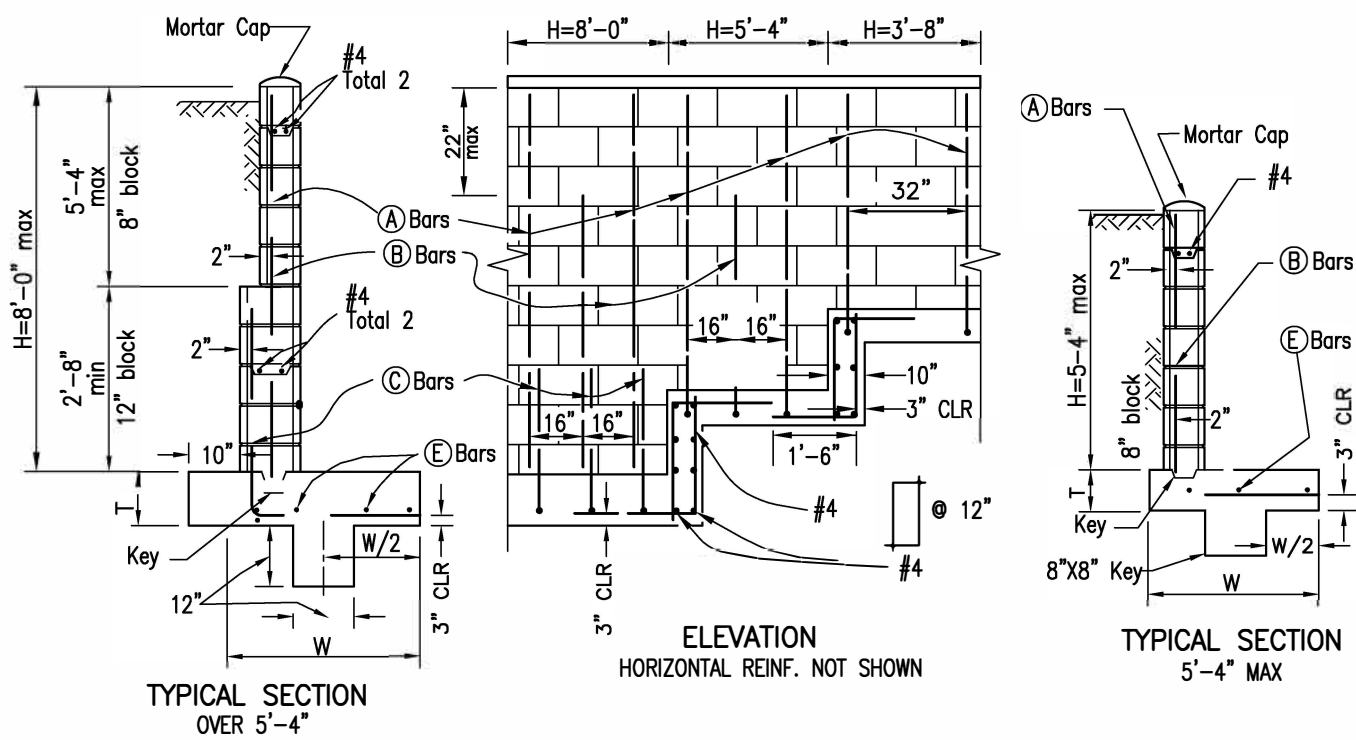
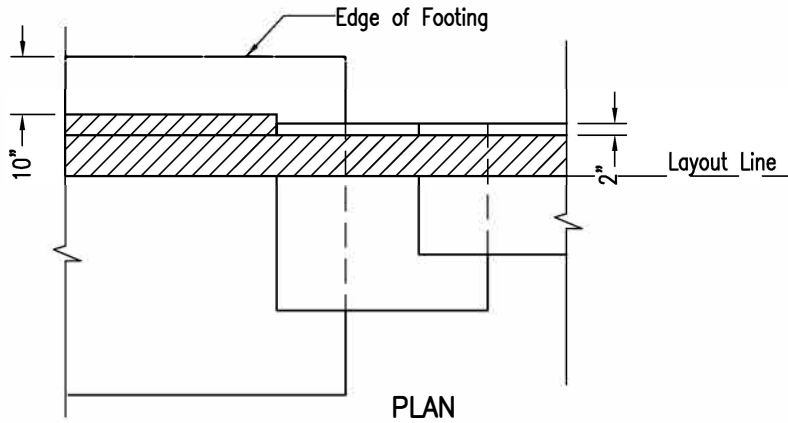

DIMENSIONS AND REINFORCING STEEL			
H (MAX)	3'-8"	5'-4"	8'-0"
T (MIN)	0'-11"	1'-0"	1'-4"
W (MIN)	2'-7"	3'-8"	5'-10"
(A) BARS	#4@32"	#4@16"	#5@24"
(B) BARS	---	#4@16"	#5@24"
(C) BARS	---	---	#6@16"
(E) BARS	#4 TOTAL 4	#4 TOTAL 5	#4 TOTAL 6
MAX SOIL PRESSURE	1500 PSF	2000 PSF	3000 PSF

NOTES: 1. SEE C-7 AND C-8 FOR ADDITIONAL NOTES AND DETAILS.
 2. FILL ALL BLOCK CELLS WITH GROUT.

Revision	By	Approved	Date	SAN DIEGO REGIONAL STANDARD DRAWING MASONRY RETAINING WALL TYPE 1 LEVEL BACKFILL WITH 10-IN HEEL	RECOMMENDED BY THE SAN DIEGO REGIONAL STANDARDS COMMITTEE <i>Saman Engeda</i> 03/24/2022 Chairperson R.C.E. 52241 Date
ORIGINAL		Kercheval	12/75		
Reviewed	TS	T. Stanton	11/15		
Updated	DH	T. Stanton	09/17		
Reviewed	RP	S. Engeda	03/22		
				DRAWING NUMBER	C-01

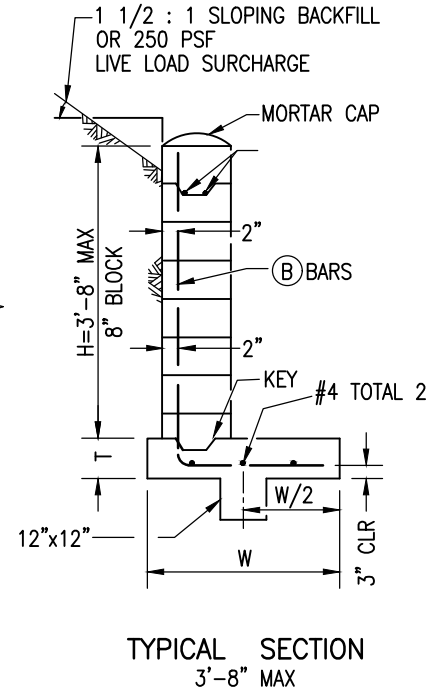
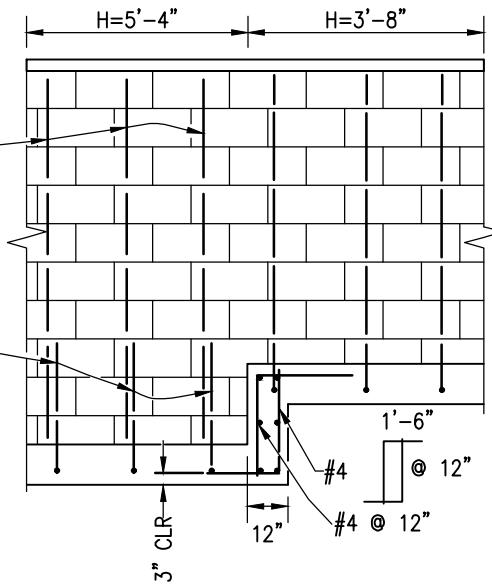
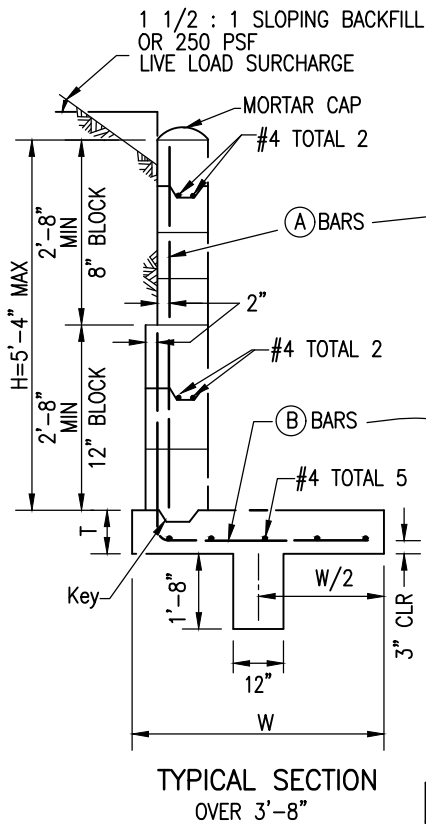
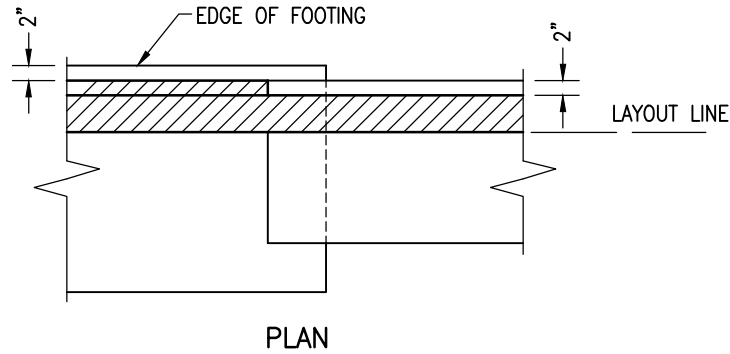

DIMENSIONS AND REINFORCING STEEL		
H (MAX)	5'-4"	3'-8"
T (MIN)	1'-1"	0'-10"
W (MIN)	5'-0"	3'-9"
(A) BARS	#4@16"	—
(B) BARS	#5@16"	#4@16"
MAX SOIL PRESSURE	1000 PSF	800 PSF

NOTES:

- SEE C-7 AND C-8 FOR ADDITIONAL NOTES AND DETAILS.
- FILL ALL BLOCK CELLS WITH GROUT.

Revision	By	Approved	Date
ORIGINAL		Kercheval	12/75
Reviewed	TS	T. Stanton	11/15
Updated	DH	T. Stanton	09/17
Reviewed	RP	S. Engeda	03/22

SAN DIEGO REGIONAL STANDARD DRAWING

MASONRY RETAINING WALL TYPE 2
(LIVE LOAD SURCHARGE OR SLOPING BACKFILL)

RECOMMENDED BY THE SAN DIEGO REGIONAL STANDARDS COMMITTEE

Samantha Engeda 03/24/2022
Chairperson R.C.E. 52241 Date

DRAWING NUMBER **C-02**

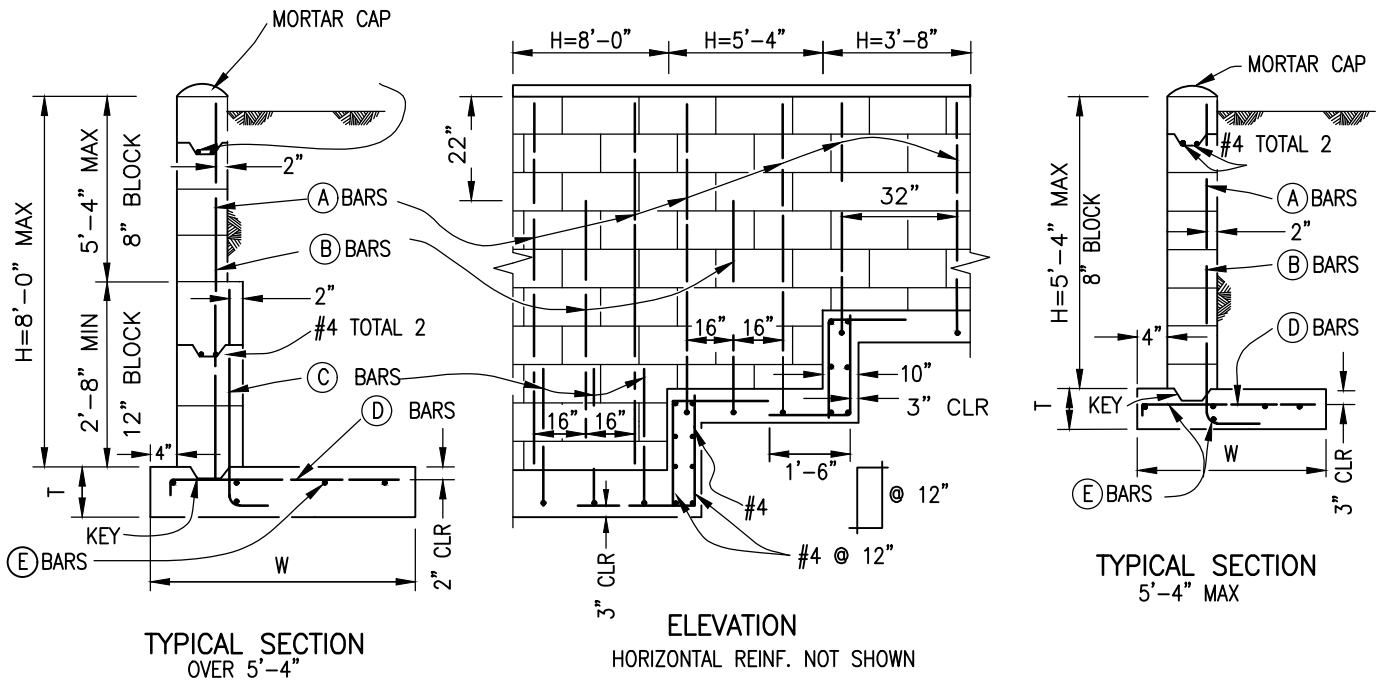
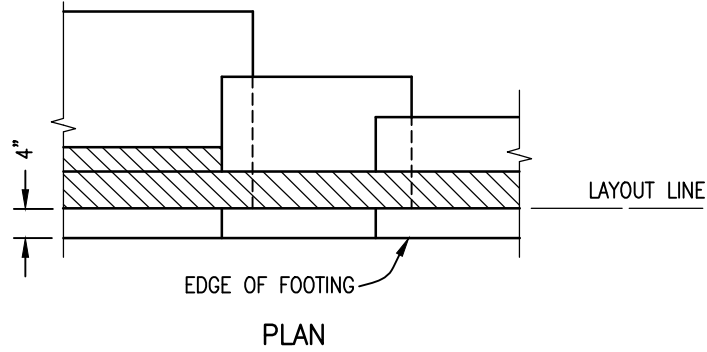

DIMENSIONS AND REINFORCING STEEL			
H (MAX)	3'-8"	5'-4"	8'-0"
T (MIN)	0'-8"	1'-1"	1'-3"
W (MIN)	2'-4"	3'-9"	5'-3"
(A) BARS	#4@32"	#5@16"	#4@24"
(B) BARS	---	#5@16"	#4@24"
(C) BARS	---	---	#6@16"
(D) BARS	#4@32"	#5@12"	#6@16"
(E) BARS	#4 TOTAL 4	#4 TOTAL 5	#4 TOTAL 6
MAX SOIL PRESSURE	1100 PSF	2500 PSF	3000 PSF

NOTES: 1. SEE C-7 AND C-8 FOR ADDITIONAL NOTES AND DETAILS.
 2. FILL ALL BLOCK CELLS WITH GROUT.

Revision	By	Approved	Date
ORIGINAL		Kercheval	12/75
Reviewed	TS	T. Stanton	11/15
Updated	DH	T. Stanton	09/17
Reviewed	RP	S. Engeda	03/22

SAN DIEGO REGIONAL STANDARD DRAWING

**MASONRY RETAINING WALL TYPE 3
(LEVEL BACKFILL)**

RECOMMENDED BY THE SAN DIEGO REGIONAL STANDARDS COMMITTEE

S. Engeda 03/24/2022
 Chairperson R.C.E. 52241 Date

DRAWING NUMBER **C-03**

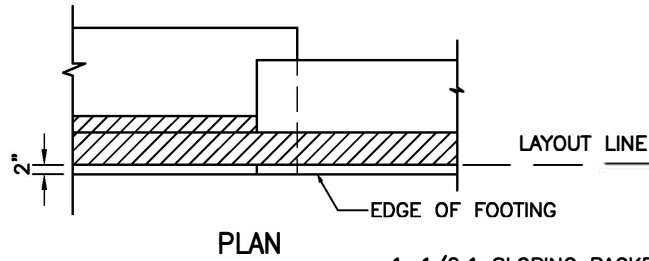

PLAN

1-1/2:1 SLOPING BACKFILL OR
250 PSF LIVE LOAD SURCHARGE

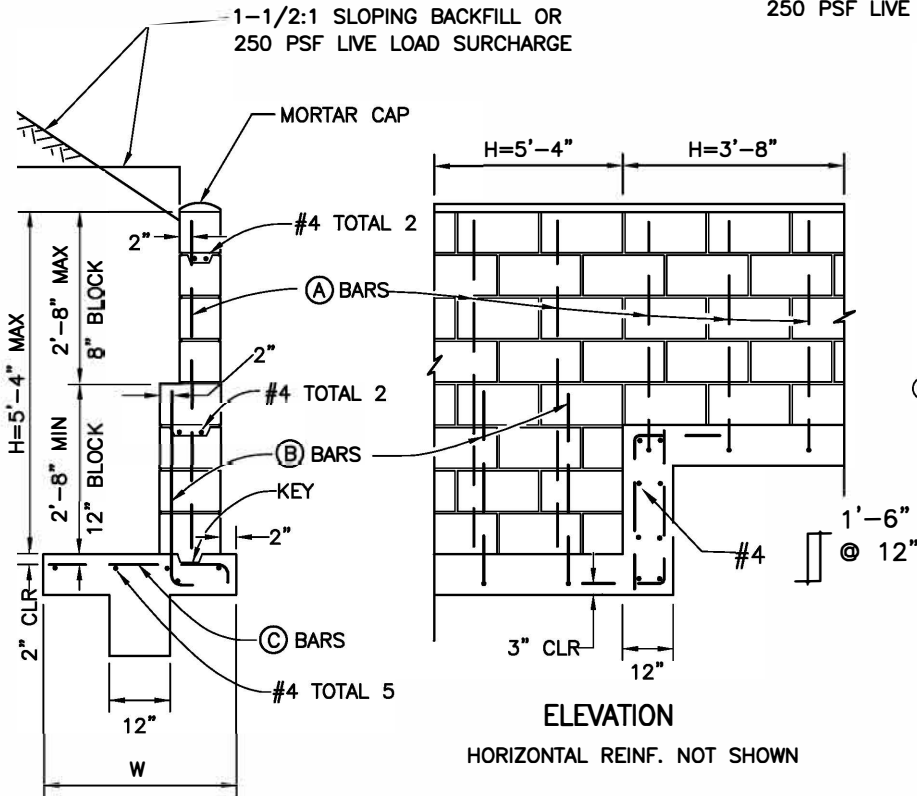

ELEVATION

HORIZONTAL REINF. NOT SHOWN

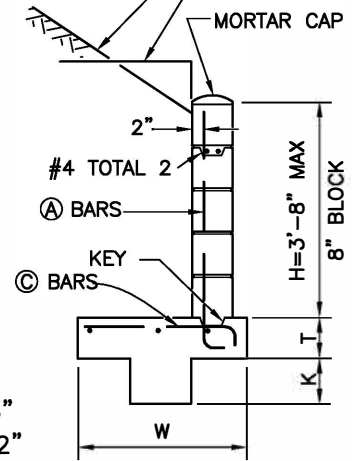

TYPICAL SECTION
3'-8" MAX

TYPICAL SECTION
OVER 3'-8"

DIMENSIONS AND REINFORCING STEEL				
H (MAX)	5'-4"		3'-8"	
T (MIN)	0'-10"		0'-8"	
W (MIN)	4'-0"		3'-0"	
(A) BARS	#4@16"		#4@16"	
(B) BARS	#6@16"		---	
SURCHARGE	sloping	live load	sloping	live load
(C) BARS	#6@8"	#6@16"	#6@16"	#6@16"
K (MIN)	1'-0"	0'-8"	1'-0"	0'-8"
TOE PRESS.	2700 PSF	1900 PSF	1700 PSF	1430 PSF

NOTES:

- SEE C-7 AND C-8 FOR ADDITIONAL NOTES AND DETAILS.
- FILL ALL BLOCK CELLS WITH GROUT.

Revision	By	Approved	Date
ORIGINAL		Parkinson	02/95
Reviewed	TS	T. Stanton	11/15
Reviewed	DH	T. Stanton	09/18
Reviewed	RP	S. Engeda	03/22

SAN DIEGO REGIONAL STANDARD DRAWING

MASONRY RETAINING WALL TYPE 4
(LIVE LOAD SURCHARGE OR SLOPING BACKFILL)

RECOMMENDED BY THE SAN DIEGO REGIONAL STANDARDS COMMITTEE

Samantha Engeda 03/24/2022
Chairperson R.C.E. 52241 Date

DRAWING NUMBER **C-04**

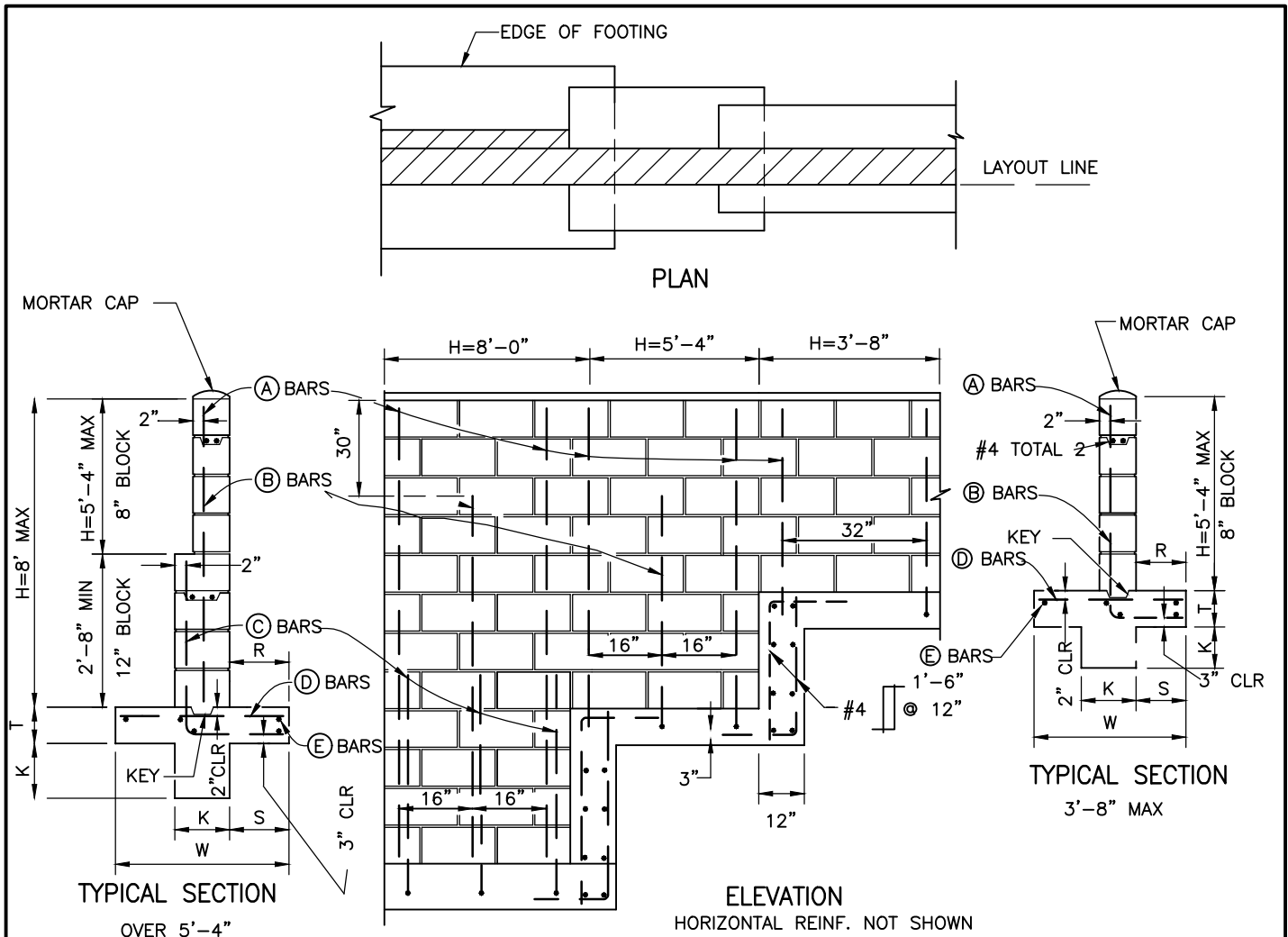

DIMENSIONS AND REINFORCING STEEL			
H (MAX)	3'-8"	5'-4"	8'-0"
T (MIN)	0'-8"	0'-10"	1'-0"
W (MIN)	2'-1"	3'-1"	4'-3"
R	0'-9"	1'-2"	1'-5"
S	0'-8 1/2"	1'-1 1/2"	1'-7 1/2"
K	0'-8"	0'-8"	1'-0"
(A) BARS	#4@32"	#4@32"	#4@32"
(B) BARS	—	#4@32"	#4@32"
(C) BARS	—	—	#7@16"
(D) BARS	#4@32"	#4@16"	#4@16"
(E) BARS	#4 total 5	#4 total 5	#4 total 6
MAX TOE PRESSURE	774 psf	1,030 psf	1,660 psf

NOTES:

1. SEE C-7 AND C-8 FOR ADDITIONAL NOTES AND DETAILS.
2. FILL ALL BLOCK CELLS WITH GROUT.

Revision	By	Approved	Date	SAN DIEGO REGIONAL STANDARD DRAWING MASONRY RETAINING WALL TYPE 5 (LEVEL BACKFILL)	RECOMMENDED BY THE SAN DIEGO REGIONAL STANDARDS COMMITTEE <i>Samantha Engeda</i> 03/24/2022 Chairperson R.C.E. 52241 Date
ORIGINAL		Parkinson	2/95		
Reviewed	TS	T. Stanton	11/15		
Reviewed	DH	T. Stanton	09/18		
Reviewed	RP	S. Engeda	03/22		
				DRAWING NUMBER	C-05

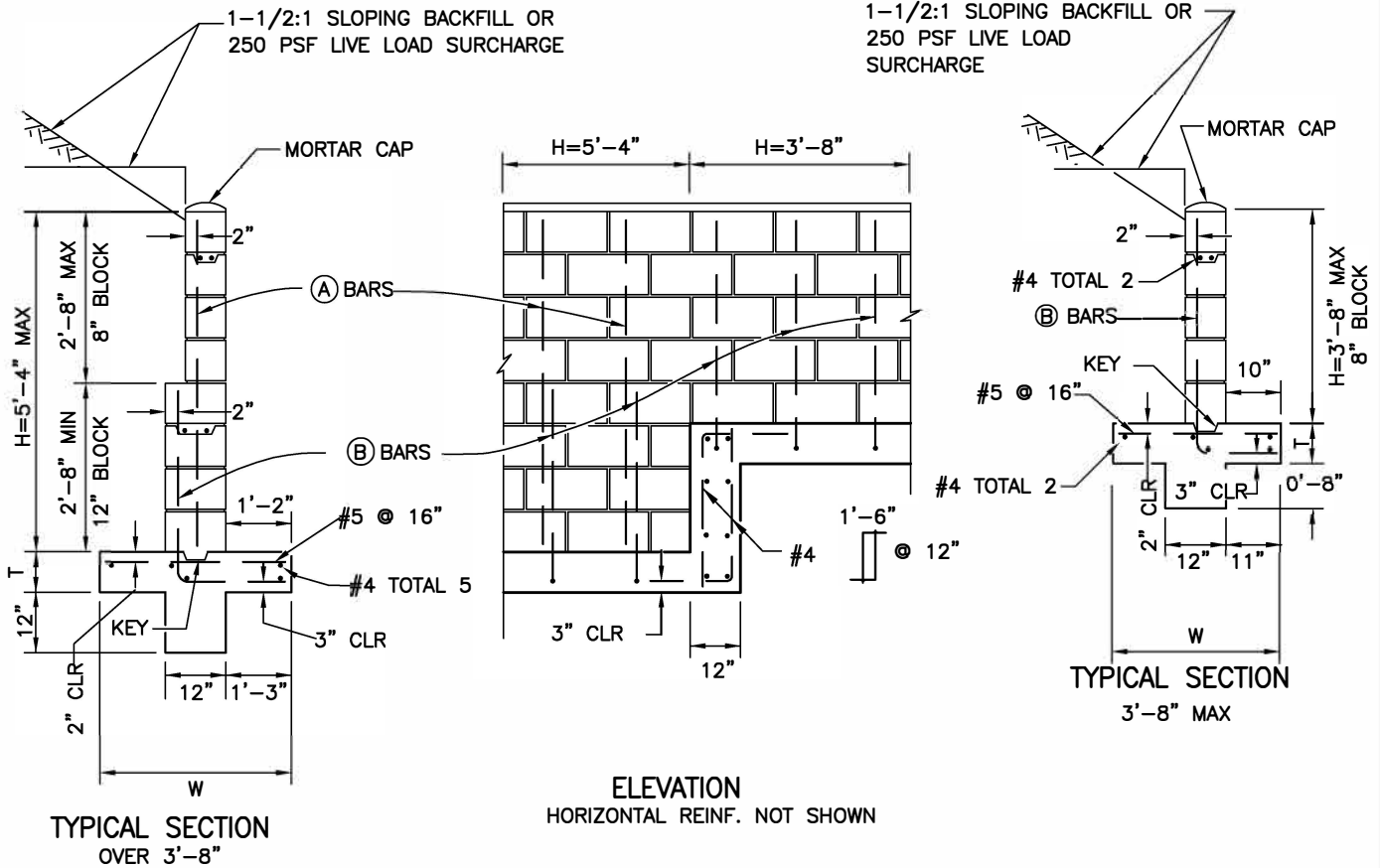
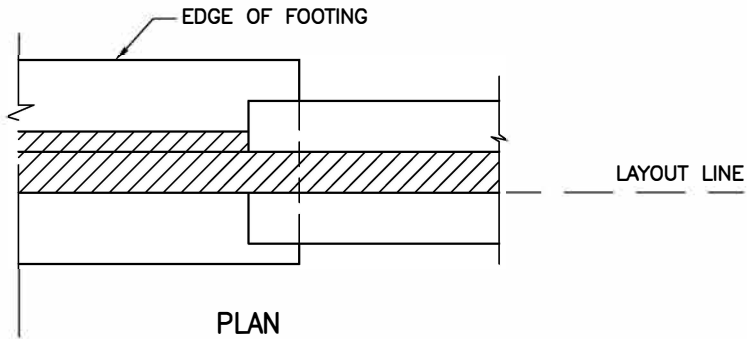

DIMENSIONS AND REINFORCING STEEL		
H (MAX)	5'-4"	3'-8"
T (MIN)	0'-10"	0'-8"
W (MIN)	3'-10"	2'-9"
(A) BARS	#4 @ 16"	---
(B) BARS	#6 @ 16"	#4 @ 16"
MAX TOE PRESSURE	2,000 PSF	1,400 PSF

NOTES:

- SEE C-7 AND C-8 FOR ADDITIONAL NOTES AND DETAILS.
- FILL ALL BLOCK CELLS WITH GROUT.

Revision	By	Approved	Date	SAN DIEGO REGIONAL STANDARD DRAWING	RECOMMENDED BY THE SAN DIEGO REGIONAL STANDARDS COMMITTEE
ORIGINAL		Parkinson	2/95		
Reviewed	TS	T. Stanton	11/15		
Reviewed	DH	T. Stanton	09/18		
Reviewed	RP	S. Engeda	03/22		
				DRAWING NUMBER C-06	

DESIGN CONDITIONS:

Walls are to be used for the loading conditions shown for each type wall. Design H shall not be exceeded. Footing key is required except as shown otherwise or when found unnecessary by the Engineer. Special footing design is required where foundation material is incapable of supporting toe pressure listed in table.

DESIGN DATA:

Reinforced Concrete:

Fc=1200 psi F'c=3000 psi
Fs=20,000 psi n=10

Reinforced Masonry:

F'm=600 psi Fm=200 psi
Fs=20,000 psi n=50
Earth=120 pcf and Equivalent Fluid
Pressure=36 psf per foot of height

Walls shown for 1 1/2:1 unlimited sloping surcharge are designed in accordance with Rankline's formula for unlimited sloping surcharge with a $\phi = 33^{\circ}42'$.

REINFORCEMENT:

Intermediate grade, hard grade, or rail steel deformation shall conform ASTM A615, A616, A617. Bars shall lap 40 diameters, where spliced, unless otherwise shown on the plans. Bends shall conform to the Manual of Standard Practice, A.C.1. Backing for hooks is four diameters. All bar embedments are clear distances to outside of bar. Spacing for parallel bars is center to center bars.

MASONRY:

All reinforced masonry retaining walls be constructed of regular or light weight standard units conforming to the "Standard Specifications for Public Works Construction."

JOINTS:

Vertical control joints shall be placed at 32' intervals maximum. Joints shall be designed to resist shear and other lateral forces while permitting longitudinal movement. Vertical expansion joints shall be placed at 96' intervals maximum.

CONCRETE:

Footing concrete shall be 560-C-3250, using Type B aggregate when placing conditions permit.

BACKFILL:

No backfill material shall be placed against masonry retaining walls until grout has reached design strength or until grout has cured for a minimum of 28 days. Compaction of backfill material by jetting or ponding with water will not be permitted. Each layer of backfill shall be moistened as directed by the Engineer and thoroughly tamped, rolled or otherwise compacted until the relative compacting is not less than 90%.

FENCING:

Safety fencing shall be installed at the top of the wall as required by the agency.

INSPECTIONS:

Call for inspections as follows:

- A. When the footing has been formed, with the steel tied securely in final position, and is ready for the concrete to be placed.
- B. Where cleanout holes are not provided:
 - (1) After the blocks have been laid up to a height of 4' or full height for walls up to 5', with steel in place but before the grout is poured, and.....
 - (2) After the first lift is properly grouted, the blocks have been laid up to the top of the wall with the steel tied securely in place but before the upper lift is grouted.

Where cleanout holes are provided:

After the blocks have been laid up to the top of the wall, with the steel tied securely in place, but before grouting.

- C. After grouting is complete and after rock or rubble wall drains are in place but before earth backfill is placed.
- D. Final inspection when all work has been completed.

CONCRETE GROUT AND MORTAR MIXES:

Concrete grout shall attain a minimum compressive strength of 2,000 psi in 28 days and mortar shall attain 1,800 psi in 28 days.

All cells shall be filled with grout. Rod or vibrate consolidation. Bring grout within 10 minutes of pouring to insure grout to a point 2" from the top of masonry units when grouting of second lift is to be continued at another time.

MORTAR KEY:

To insure proper bonding between the footing and the first course of block, a mortar key shall be formed by embedding a flat 2 x 4 flush with and at the top of the freshly poured footing. The 2 x 4 should be removed after the concrete has started to harden (approximately 1 hour).

A mortar key may be omitted if the first course of block is set into the fresh concrete when the footing is poured, and a good bond is obtained.

WALL DRAINS:

Wall drains shall be provided in accordance with Standard Drawing C-8.

SOIL:

All footings shall extend at least 12" into undisturbed natural soil or approved compacted fill. Soil should be dampened prior to placing concrete in footings.

Revision	By	Approved	Date
ORIGINAL		A. Kercheval	12/75
Reviewed	GT	T. Stanton	09/15
Reviewed	DH	T. Stanton	09/18
Reviewed	RP	S. Engeda	03/22

SAN DIEGO REGIONAL STANDARD DRAWING

**GENERAL NOTES FOR MASONRY
RETAINING WALLS**

RECOMMENDED BY THE SAN DIEGO REGIONAL STANDARDS COMMITTEE

Samuel P. ... 03/24/2022

Chairperson R.C.E. 52241 Date

**DRAWING
NUMBER C-07**

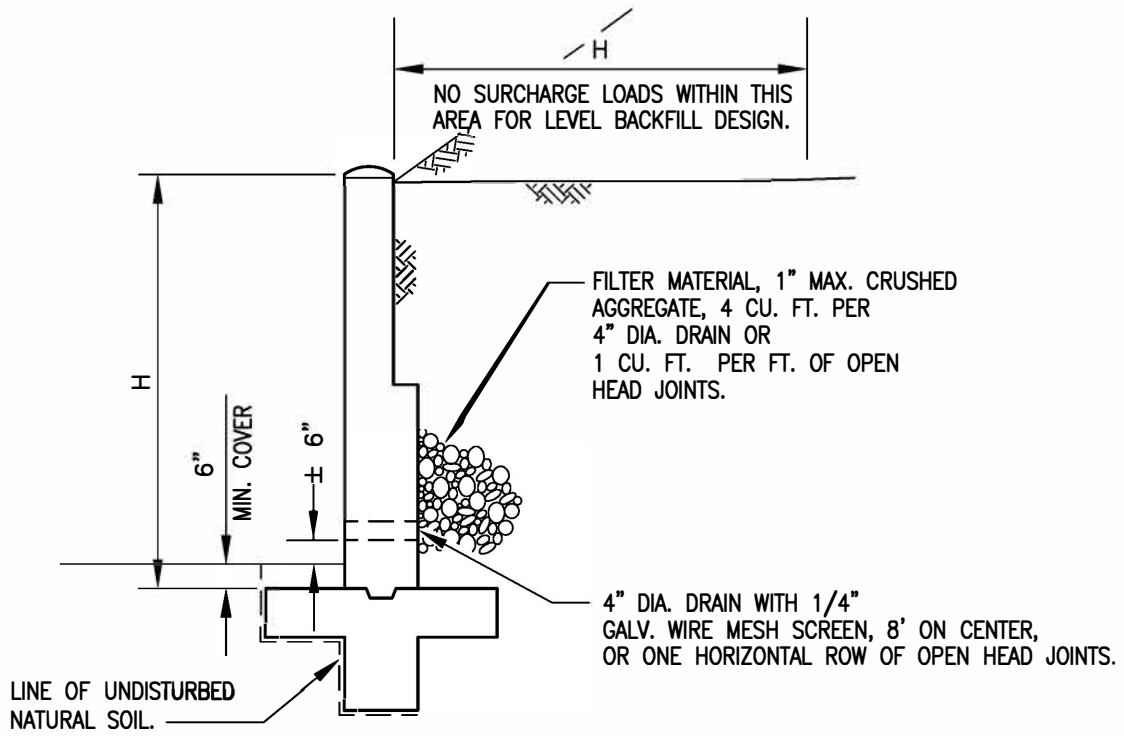

TYPICAL SECTION

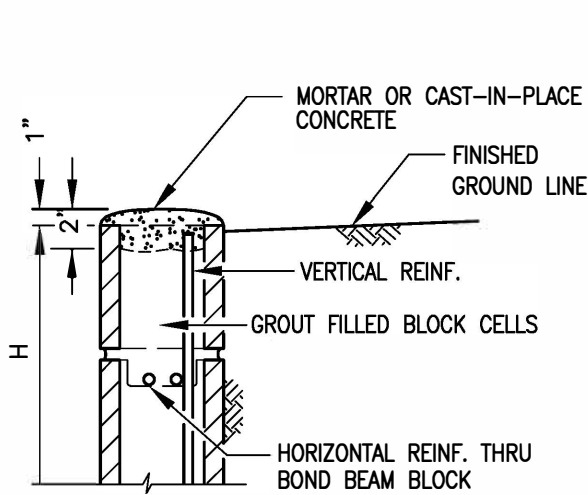

CAP DETAIL

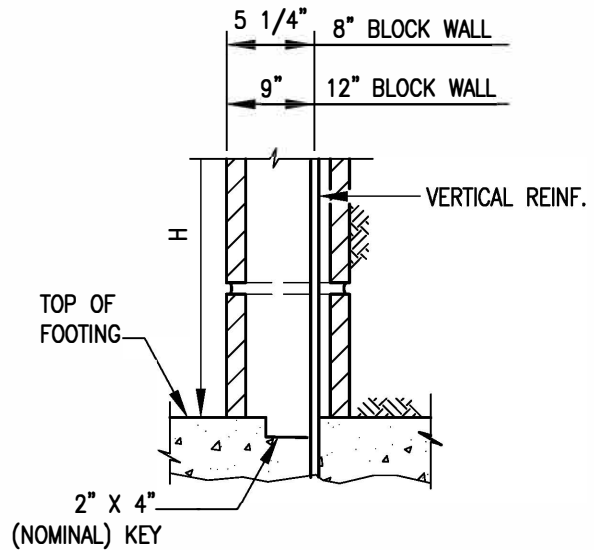

KEY DETAIL

NOTES:

1. ALL MASONRY RETAINING WALLS SHALL BE CONSTRUCTED WITH CAP, KEY AND DRAINAGE DETAILS AS SHOWN HEREON.
2. 4" DIAMETER DRAIN MAY BE FORMED BY PLACING A BLOCK ON IT'S SIDE.

Revision	By	Approved	Date
ORIGINAL		Kercheval	12/75
Reviewed	TS	T. Stanton	11/15
Reviewed	DH	T. Stanton	09/18
Reviewed	RP	S. Engeda	03/22

SAN DIEGO REGIONAL STANDARD DRAWING

DETAILS FOR MASONRY RETAINING WALL

RECOMMENDED BY THE SAN DIEGO REGIONAL STANDARDS COMMITTEE

Samantha Engeda 03/24/2022
Chairperson R.C.E. 52241 Date

DRAWING NUMBER **C-08**

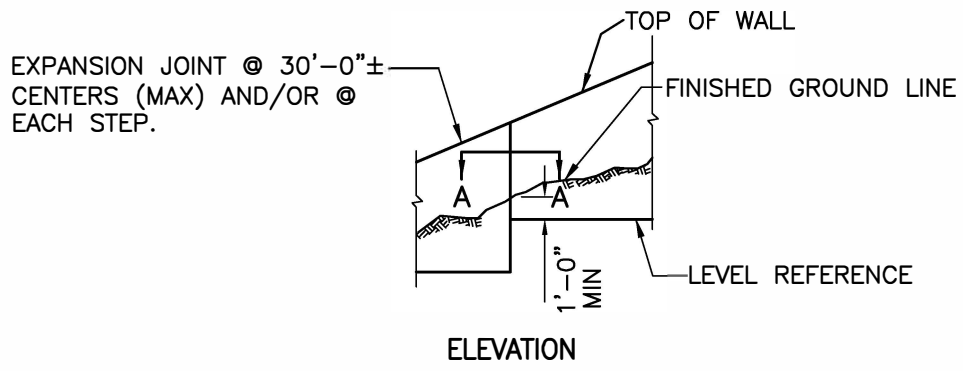
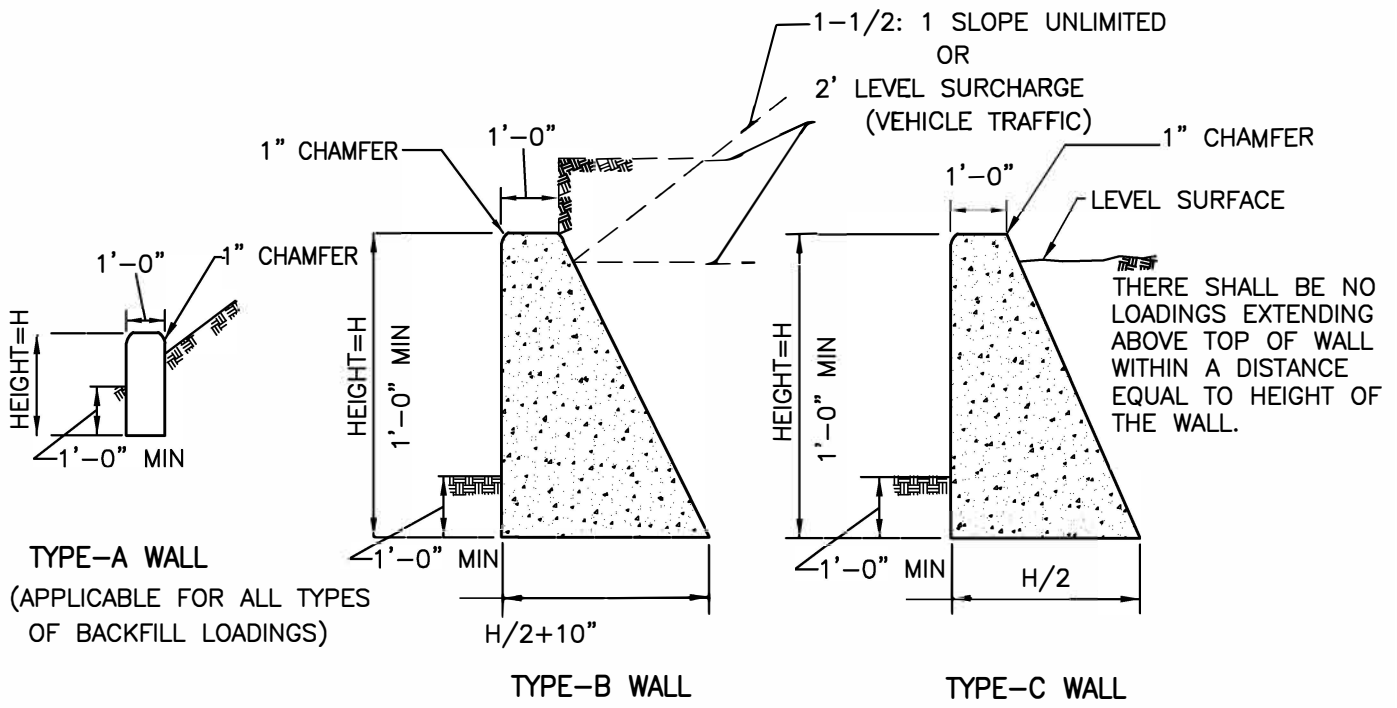

WALL TYPE	HEIGHT	BASE	CONCRETE CF/FT
A	1'-6"	1'-0"	1.50 cu ft.
	2'-0"	1'-0"	2.00 cu ft.
B	3'-0"	2'-4"	4.99 cu ft.
	4'-0"	2'-10"	7.66 cu ft.
	5'-0"	3'-4"	10.82 cu ft.
	6'-0"	3'-10"	14.49 cu ft.
C	3'-0"	1'-6"	3.75 cu ft.
	4'-0"	2'-0"	6.00 cu ft.
	5'-0"	2'-6"	8.75 cu ft.
	6'-0"	3'-0"	12.00 cu ft.

NOTE:
SEE C-10 FOR SECTION A-A, NOTES AND DETAILS.

Revision	By	Approved	Date	SAN DIEGO REGIONAL STANDARD DRAWING	RECOMMENDED BY THE SAN DIEGO REGIONAL STANDARDS COMMITTEE	
ORIGINAL		Kercheval	12/75		GRAVITY RETAINING WALLS	<i>Samsir Engeda</i> 03/24/2022
Reviewed	TS	T. Stanton	11/15			Chairperson R.C.E. 52241 Date
Reviewed	DH	T. Stanton	09/18			DRAWING NUMBER
Reviewed	RP	S. Engeda	03/22			C-09

CONCRETE

CONCRETE SHALL BE 560-C-3250.

DESIGN CONDITIONS

WALLS ARE TO BE USED FOR THE LOADING CONDITIONS SHOWN FOR EACH TYPE WALL. DESIGN H MAY BE EXCEEDED BY SIX INCHES BEFORE GOING TO NEXT SIZE.

DESIGN DATA

FC = 1200 PSI
 F'C = 3000 PSI
 EARTH = 120 PCF
 AND EQUIVALENT FLUID PRESSURE=36 PSF PER FOOT OF HEIGHT

WALLS SHOWN FOR 1-1/2:1 UNLIMITED SLOPING SURCHARGE ARE DESIGNED IN ACCORDANCE WITH RANKINE'S FORMULA FOR UNLIMITED SLOPING SURCHARGE WITH $\phi = 42'$.

NOTE: MAXIMUM TOE PRESSURE UNDER WALL FOOTING = 1-1/2 TONS/SQ. FT. SPECIAL DESIGN REQUIRED WHERE FOOTING MATERIAL IS INCAPABLE OF SUPPORTING THIS PRESSURE.

EXCAVATION AND BACKFILL

COMPACTION OF BACKFILL MATERIAL BY JETTING OR PONDING WITH WATER WILL NOT BE PERMITTED.

EACH LAYER OF BACKFILL SHALL BE MOISTENED AS DIRECTED BY THE ENGINEER AND THOROUGHLY TAMPED, ROLLED OR OTHERWISE COMPACTED UNTIL THE RELATIVE COMPACTION IS NOT LESS THAN 90 PERCENT.

NO BACKFILL MATERIAL SHALL BE DEPOSITED AGAINST CONCRETE RETAINING WALLS UNTIL THE CONCRETE HAS DEVELOPED A STRENGTH OF 2,500 PSI IN COMPRESSION AS DETERMINED BY TEST CYLINDERS, OR UNTIL 28 DAYS AFTER WALL HAS BEEN PLACED.

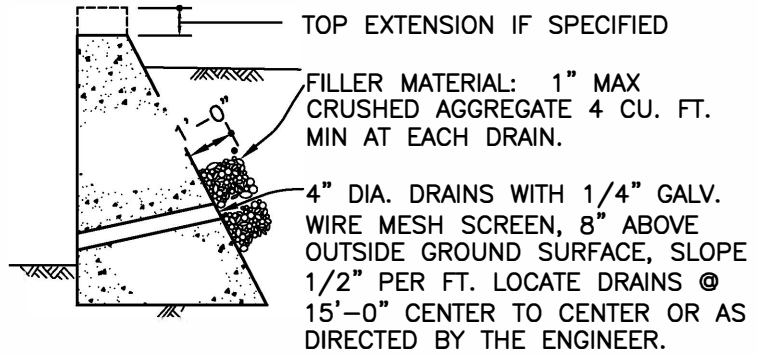

TYPICAL DRAINAGE

WHEN H IS GREATER THAN 4'-0"

1/2" EXPANSION JOINT, FILL WITH PREMOLDED EXPANSION JOINT FILLER. LOCATE JOINTS AT APPROX. 30'-0" CENTERS OR AS DIRECTED BY THE ENGINEER.

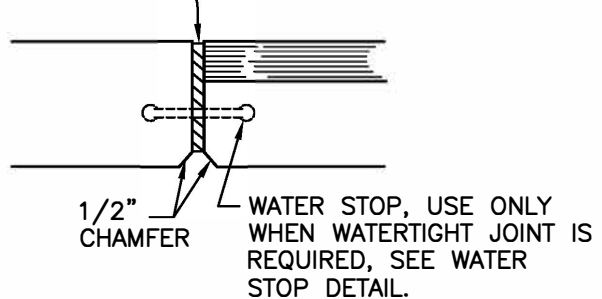

SECTION A-A

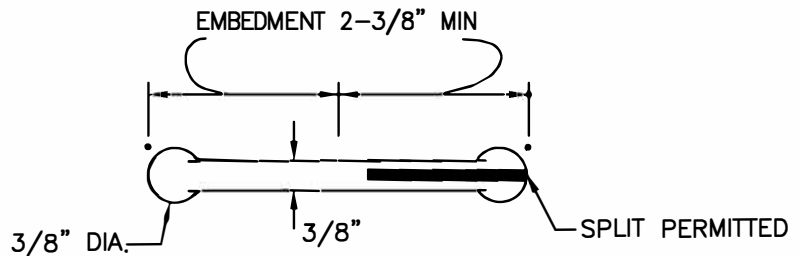

RUBBER WATERSTOP

USE ONLY WHEN WATERTIGHT JOINT IS REQUIRED.

Revision	By	Approved	Date
ORIGINAL		Kercheval	12/75
Reviewed	TS	T. Stanton	11/15
Reviewed	DH	T. Stanton	09/18
Reviewed	RP	S. Engeda	03/22

SAN DIEGO REGIONAL STANDARD DRAWING

GENERAL NOTES AND DETAILS FOR GRAVITY RETAINING WALLS

RECOMMENDED BY THE SAN DIEGO REGIONAL STANDARDS COMMITTEE

Samantha Engeda 03/24/2022
 Chairperson R.C.E. 52241 Date

DRAWING NUMBER **C-10**

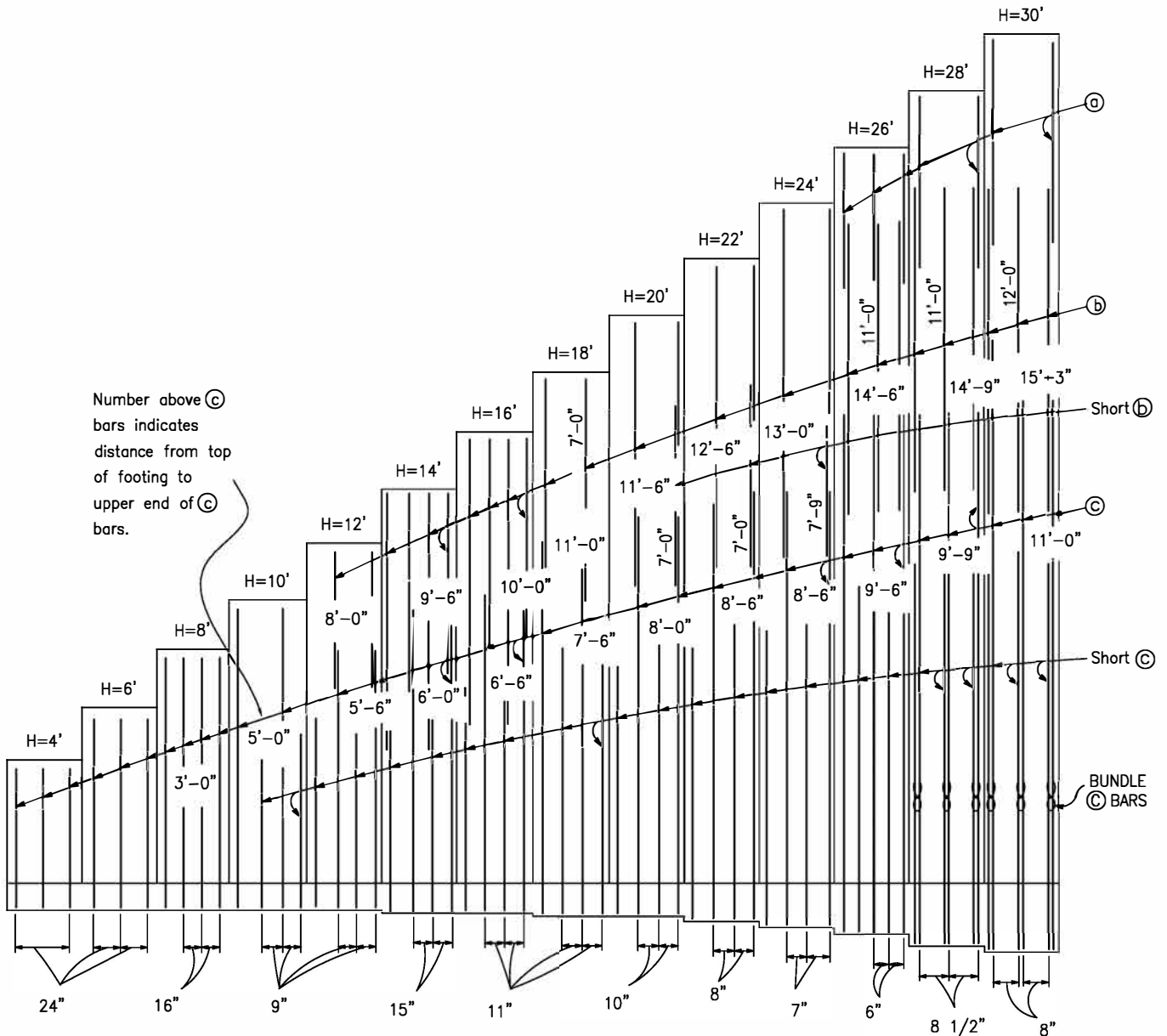

ELEVATION

NOTES:

1. FOR SPREAD FOOTING SECTION SEE C-11B
2. FOR TYPICAL LAYOUT EXAMPLE SEE C-11C
3. FOR 45T PILE FOOTING SECTION SEE C-11C
4. FOR TABLE OF REINFORCING STEEL DIMENSIONS AND DATA SEE C-11D

Revision	By	Approved	Date
ORIGINAL		Kercheval	12/75
Reviewed	TS	T. Stanton	11/15
Reviewed	DH	T. Stanton	08/18
Reviewed	RP	S. Engeda	03/22

SAN DIEGO REGIONAL STANDARD DRAWING

REINFORCED CONCRETE RETAINING WALL

TYPE 1 - ELEVATION

RECOMMENDED BY THE SAN DIEGO REGIONAL STANDARDS COMMITTEE

S. Engeda 03/24/2022
 Chd Engeda R.C.E. 52241 Date

DRAWING NUMBER C-11A

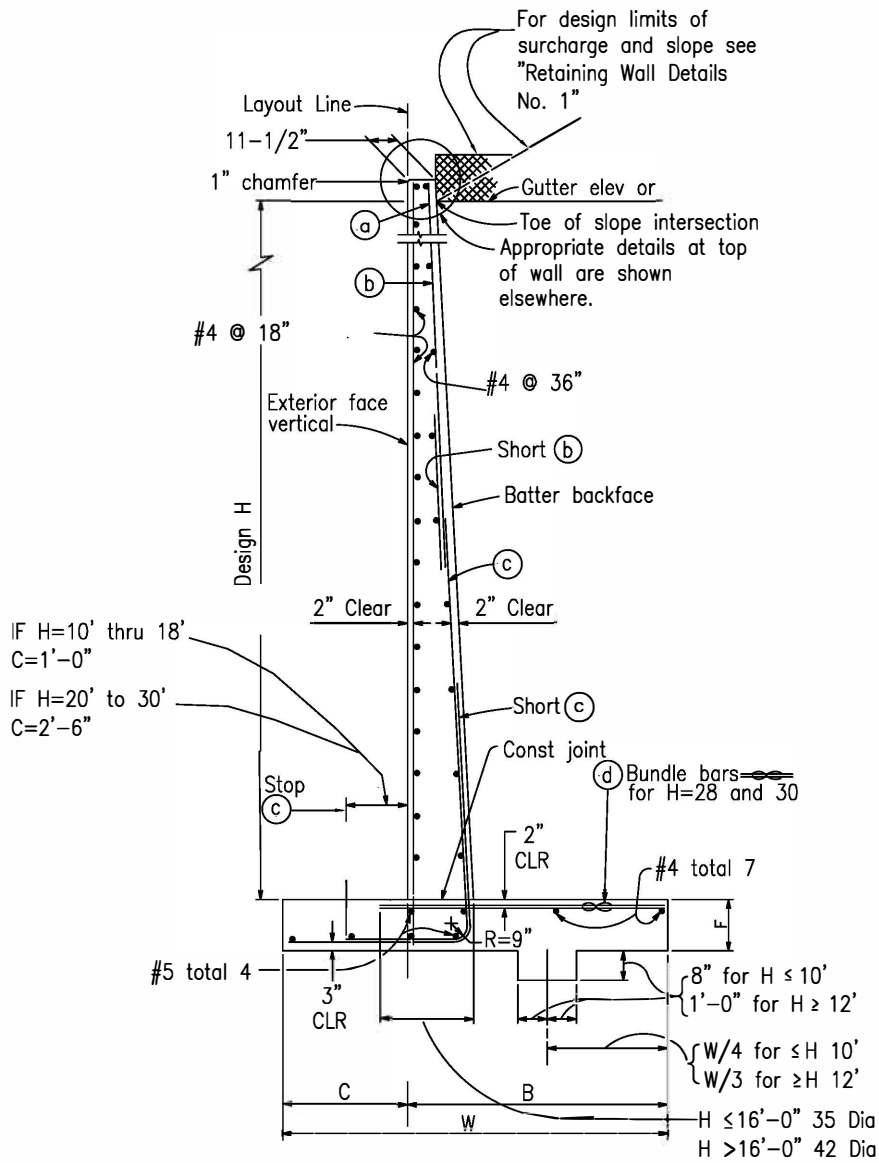

SPREAD FOOTING SECTION

NOTES:

- FOR DETAILS NOT SHOWN AND DRAINAGE NOTES SEE "RETAINING WALL DETAILS NO.1".
STANDARD DRAWINGS C-13A TO C-13D.
- QUANTITIES APPLY TO DESIGN H PORTION AND EXCLUDE THE ADDED PORTION ABOVE "GUTTER ELEVATION".

Revision	By	Approved	Date
ORIGINAL		Kercheval	12/75
Revised	TS	T. Stanton	11/15
Revised	DH	T. Stanton	09/18
Reviewed	RP	S. Engeda	03/22

SAN DIEGO REGIONAL STANDARD DRAWING

REINFORCED CONCRETE RETAINING WALL

TYPE 1 - SPREAD FOOTING

RECOMMENDED BY THE SAN DIEGO REGIONAL STANDARDS COMMITTEE

S. Engeda 03/24/2022
Chairperson R.C.E. 52241 Date

DRAWING NUMBER C-11B

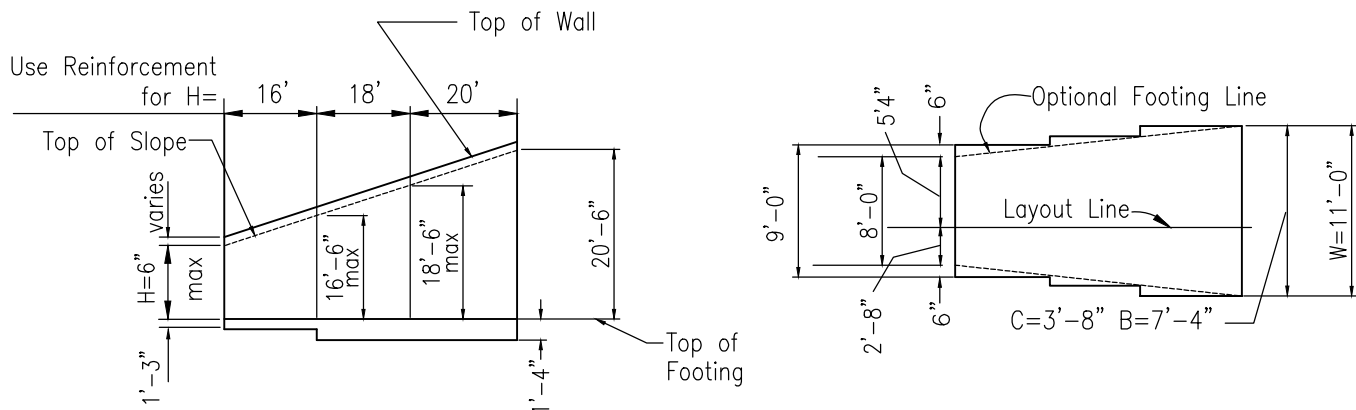

TYPICAL LAYOUT EXAMPLE

FOR JOINTS REQUIRED, SEE DETAILS 3-3 AND 3-4, DRAWING C-15

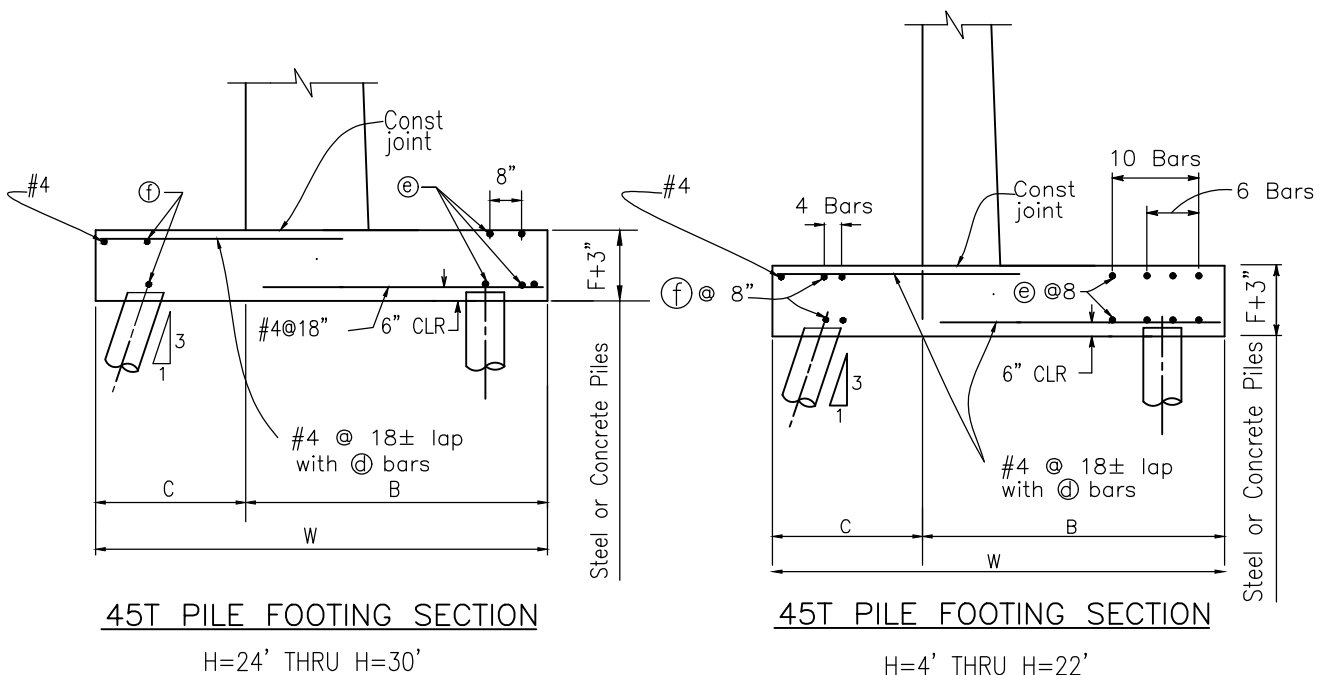

45T PILE FOOTING SECTION
H=24' THRU H=30'

45T PILE FOOTING SECTION
H=4' THRU H=22'

Revision	By	Approved	Date	SAN DIEGO REGIONAL STANDARD DRAWING		RECOMMENDED BY THE SAN DIEGO REGIONAL STANDARDS COMMITTEE
ORIGINAL		Kercheval	12/75	REINFORCED CONCRETE RETAINING WALL TYPE 1 - PILE FOOTING		<i>Saman Engeda</i> 03/24/2022 Chairperson R.C.E. 52241 Date
Reviewed	TS	T. Stanton	11/15			
Reviewed	DH	T. Stanton	09/18			
Reviewed	RP	S. Engeda	03/22			
						DRAWING NUMBER C-11C

TABLE OF REINFORCING STEEL DIMENSIONS AND DATA

Design H	4'	6'	8'	10'	12'	14'	16'	18'	20'	22'	24'	26'	28'	30'
W	3'-2"	4'-2"	5'-2"	6'-2"	7'-2"	8'-0"	9'-0"	10'-0"	11'-0"	12'-0"	13'-3"	14'-3"	15'-3"	16'-9"
C	1'-0"	1'-4"	1'-8"	2'-0"	2'-4"	2'-8"	3'-0"	3'-4"	3'-8"	4'-0"	4'-5"	4'-9"	5'-1"	5'-5"
B	2'-2"	2'-10"	3'-6"	4'-2"	4'-10"	5'-4"	6'-0"	6'-8"	7'-4"	8'-0"	8'-10"	9'-6"	10'-2"	11'-4"
F Spread Ftg.	1'-2"	1'-2"	1'-2"	1'-2"	1'-2"	1'-3"	1'-3"	1'-4"	1'-4"	1'-6"	1'-8"	1'-11"	2'-2"	2'-4"
Batter	1/2:12	1/2:12	1/2:12	1/2:12	1/2:12	1/2:12	1/2:12	1/2:12	1/2:12	1/2:12	5/8:12	3/4:12	3/4:12	7/8:12
⊙bars	—	—	—	—	—	—	—	—	—	—	—	#6@24	#6@17	#6@16
⊙bars	—	—	—	—	#4@18	#6@30	#6@22	#7@22	#8@20	#8@16	#8@14	#8@12	#8@8-1/2	#8@8
⊙bars	#5@24	#5@24	#5@16	#5@9	#6@9	#9@15	#9@11	#10@11	#11@10	#11@8	#11@7	#11@6	#10@8-1/2	#10@8
⊙bars	#5@24	#5@24	#4@16	#4@9	#5@9	#8@15	#8@11	#10@11	#10@11	#10@8	#10@7	#10@6	#9@8-1/2	#9@8
Total ⊕ bars	6-#6	6-#6	10-#7	10-#7	10-#7	10-#7	6-#7	6-#7	6-#7	6-#7	4-#7	4-#7	4-#7	4-#7
Total ⊕ bars				4-#7	4-#7	4-#7	4-#7	4-#7	4-#7	4-#7	2-#7	2-#7	2-#7	2-#7
2' Level surcharge	1.6	1.9	2.2	2.3	2.8	3.3	3.5	4.0	4.3	4.6	4.9	5.3	5.7	6.2
2:1 unlimited slope	1.1	1.5	2.0	2.5	2.7	3.3	3.6	4.2	4.7	5.5	5.9	6.5	7.1	7.5
1-1/2:1 limited slope	1.3	1.7	2.1	2.5	2.9	3.4	3.8	4.3	4.8	5.4	5.8	6.5	7.2	7.5
Spread Footing	17	20	28	37	51	80	105	147	187	246	303	407	449	507
Conc cf/ft	8.9	12.5	16.3	20.2	25.4	30.1	34.6	40.1	45.0	52.1	63.3	77.0	88.1	104.8
Pile ftg.	29	32	41	70	84	113	140	172	212	270	322	427	469	528
Conc cf/ft	10.2	12.7	16.7	20.8	25.2	30.1	34.8	40.6	45.7	53.1	64.7	78.6	89.9	107.0

Note: Reinforcement detailed is to be placed in addition to that shown for spread footing. All piles not shown, see Pile Layout on plans. *For pile footing Design H=4' use same footing dimensions as Design H=6' †Denotes a bundle of 2 bars

Revision	By	Approved	Date
ORIGINAL		Kercheval	12/75
Reviewed	TS	T. Stanton	11/15
Reviewed	DH	T. Stanton	09/18
Reviewed	RP	S. Engeda	03/22

SAN DIEGO REGIONAL STANDARD DRAWING

**REINFORCED CONCRETE RETAINING WALL
TYPE 1 - DIMENSION AND STEEL TABLE**

RECOMMENDED BY THE SAN DIEGO REGIONAL STANDARDS COMMITTEE

Samantha Engeda 03/24/2022
Chairperson R.C.E. 52241 Date

DRAWING NUMBER C-11D

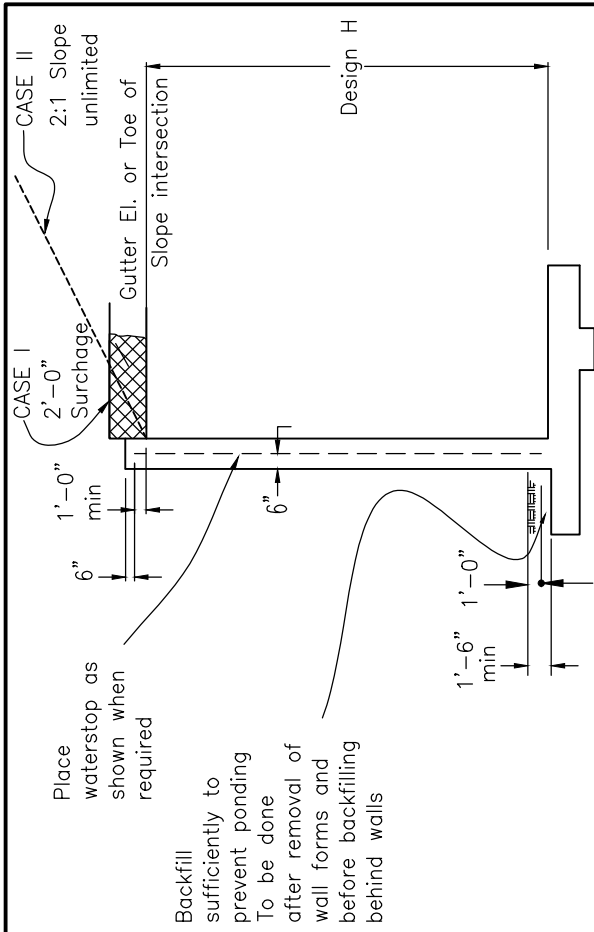

DESIGN

For drainage notes and other details, see "Retaining Wall Details No.1" Drawing C-13A to C-13D

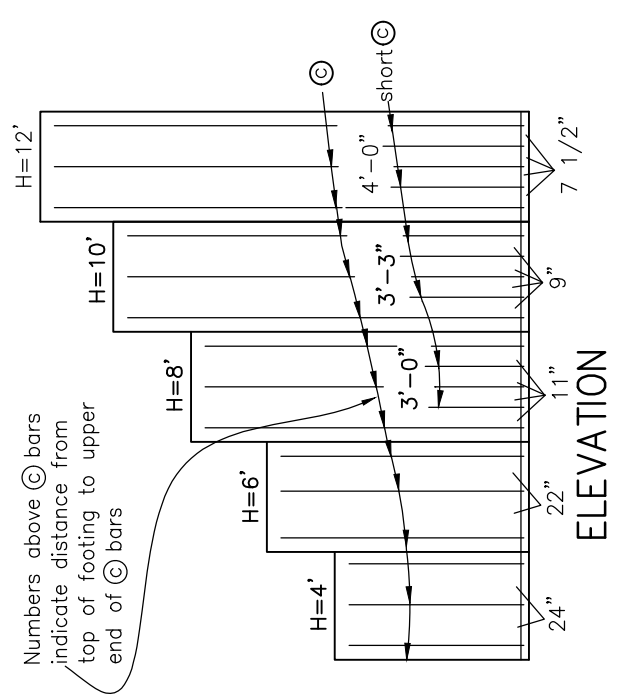

ELEVATION

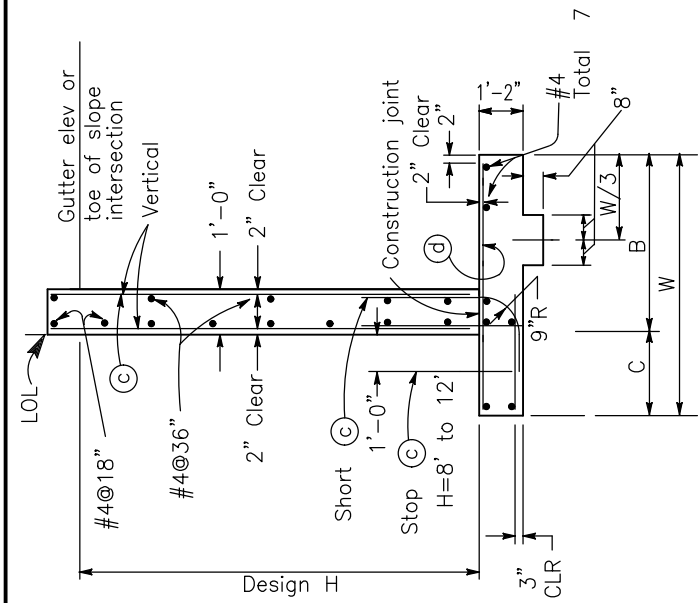

SPREAD FOOTING SECTION

Place concrete in toe against undisturbed material, except as permitted by the Engineer.

NOTES:

Design H may be exceeded by 6" before going to the next size. Footing key is required except when found unnecessary by Engineer. Special footing design is required where foundation material is incapable of supporting toe pressure loads listed in table.

Design Data:

$f_c = 1300$ psi $f'_c = 3250$ psi $f_s = 24,000$ psi $n = 10$ earth 120 pcf

Case I - Equivalent fluid pressure = 36 psf max for determination of toe pressure. 27 psf min for determination of heel pressure.

Case II - Earth pressure determined from Rankine's formula with $O = 33^\circ - 42^\circ$.

NOTE:

Reinforcement detailed is to be placed in addition to that shown for spread footing. All piles not shown. see Pile Layout on plans.

Revision	By	Approved	Date
ORIGINAL		Kercheval	12/75
Reviewed	TS	T. Stanton	11/15
Reviewed	DH	T. Stanton	09/18
Reviewed	RP	S. Engeda	03/22

SAN DIEGO REGIONAL STANDARD DRAWING

REINFORCED CONCRETE RETAINING WALL

TYPE 1A

RECOMMENDED BY THE SAN DIEGO REGIONAL STANDARDS COMMITTEE

Samantha Engeda 03/24/2022
Chairperson R.C.E. 52241 Date

DRAWING NUMBER C-12A

Revision	By	Approved	Date
ORIGINAL		Kercheval	12/75
Reviewed	TS	T. Stanton	11/15
Reviewed	DH	T. Stanton	19/18
Reviewed	RP	S. Engeda	03/22

SAN DIEGO REGIONAL STANDARD DRAWING

REINFORCED CONCRETE RETAINING WALL

TYPE 1A

RECOMMENDED BY THE SAN DIEGO REGIONAL STANDARDS COMMITTEE

Saman Engeda 03/24/2022
Chairperson R.C.E. 52241 Date

DRAWING NUMBER C-12B

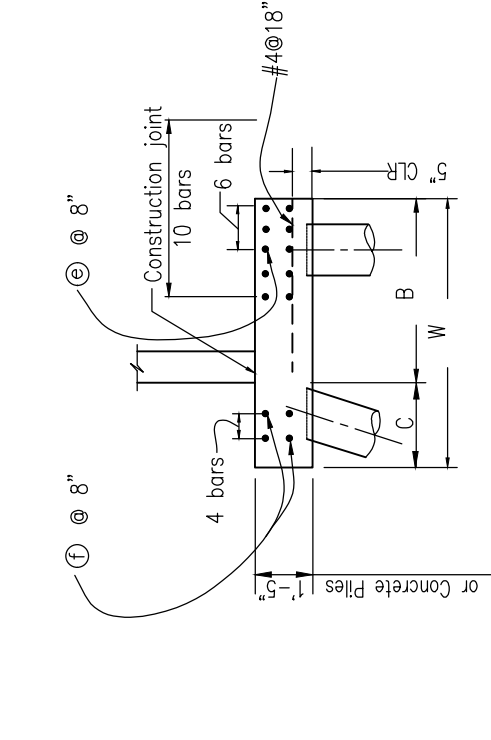

45T PILE FOOTING SECTION

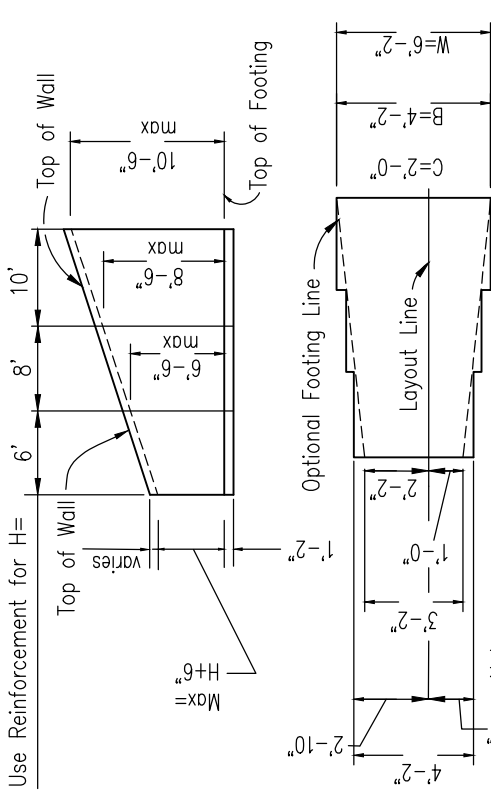

TYPICAL LAYOUT EXAMPLE

For joints required, see Details 3-3 and 3-4, Std Dwg C-15

Note:
Bar cut-offs may be varied in increments of 6"

TABLE OF REINFORCING STEEL DIMENSIONS AND DATA

Design H	* 4'	6'	8'	10'	12'
W	3'-2"	4'-2"	5'-2"	6'-2"	7'-2"
C	1'-0"	1'-4"	1'-8"	2'-0"	2'-4"
B	2'-2"	2'-10"	3'-6"	4'-2"	4'-10"
© bars	#5@24"	#5@22"	#5@11"	#6@9"	#7@7-1/2"
© bars	#5@24"	#5@22"	#5@22"	#7@18"	#8@15"
Total © bars	6-#6	6-#6	6-#6	10-#7	10-#7
Total © bars	6-#6	6-#6	6-#6	4-#7	4-#7
Case I - Toe Press.	1590psf	1930psf	2240psf	2550psf	2840psf
Case II - Toe Press.	1060psf	1460psf	1860psf	2280psf	2700psf
Spread Steel lbs/ft	15lb	21lb	27lb	46lb	70lb
Footings Conc CF/ft	8.6lb	11.8lb	14.9lb	18.1lb	21.3lb
Pile Ftg Steel lbs/ft	25lb	32lb	38lb	75lb	101lb
Conc CF/ft	9.9lb	11.9lb	15.3lb	18.8lb	22.2lb

Note:
Quantities apply to Design H portion and exclude the added portion above "Gutter Elevation". *For pile footing Design H=4' use same footing dimensions as Design H=6'.

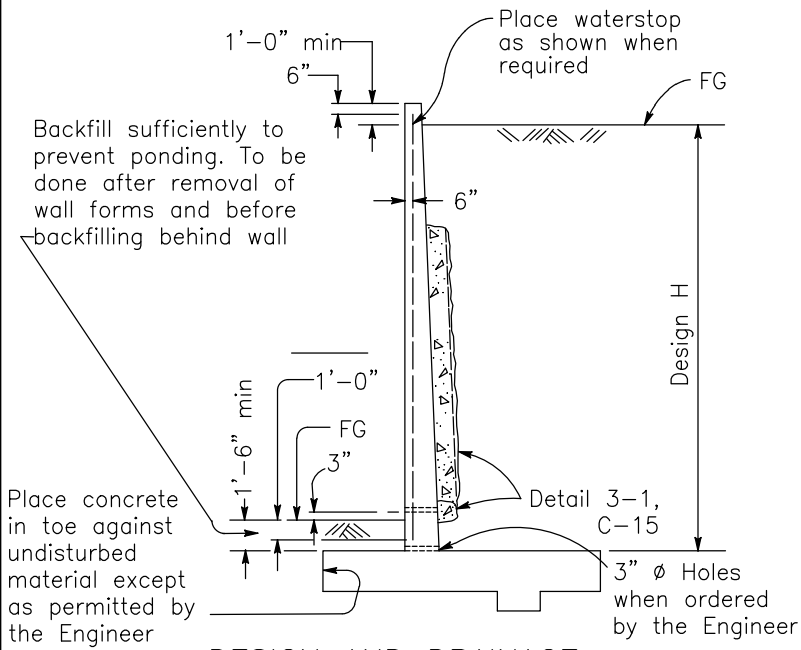

DESIGN AND DRAINAGE

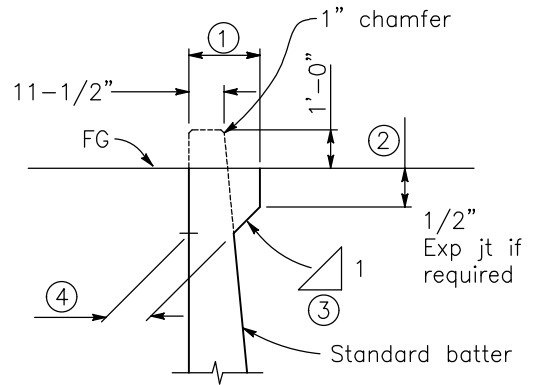

Dimensions ①, ② and ③ to be as shown elsewhere in the project plans
④ Stem width at base of haunch to be determined as shown

STEM WIDTH AT BASE OF HAUNCH

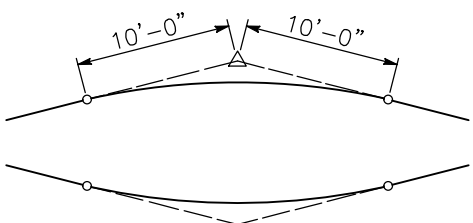

20' VC AT TOP OF WALL SLOPE CHANGE

Where shown on the plans

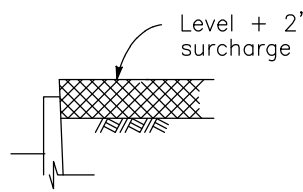

CASE I

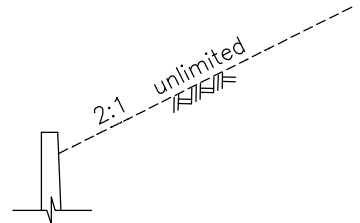

CASE II

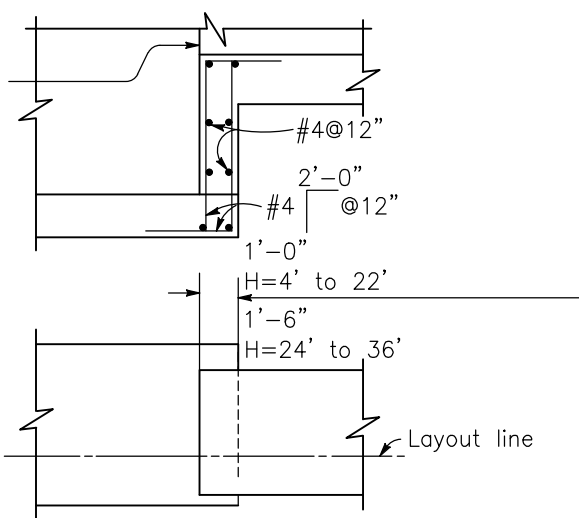

FOOTING STEP

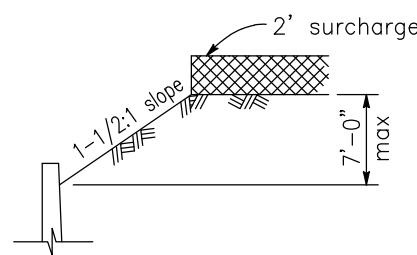

CASE III

DETAIL OF DESIGN LOADING CASES

- CASE I Level + 2' surcharge
- CASE II 2:1 unlimited slope
- CASE III 1-1/2:1 limited slope (7'-0" max height) + 2' surcharge

NOTE: Surcharge limits shown apply to retaining walls Type 1 and 3

Revision	By	Approved	Date
ORIGINAL		Kercheval	12/75
Reviewed	TS	T. Stanton	11/15
Reviewed	DH	T. Stanton	09/18
Reviewed	RP	S. Engeda	03/22

SAN DIEGO REGIONAL STANDARD DRAWING

REINFORCED CONCRETE

RETAINING WALL DETAILS No. 1

RECOMMENDED BY THE SAN DIEGO REGIONAL STANDARDS COMMITTEE

Saman Engeda 03/24/2022
Chairperson R.C.E. 52241 Date

DRAWING NUMBER **C-13A**

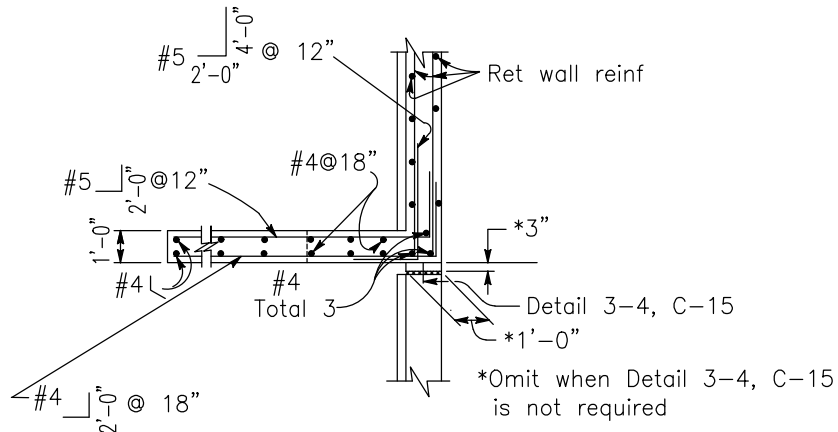

PLAN

(For return wall type "A")

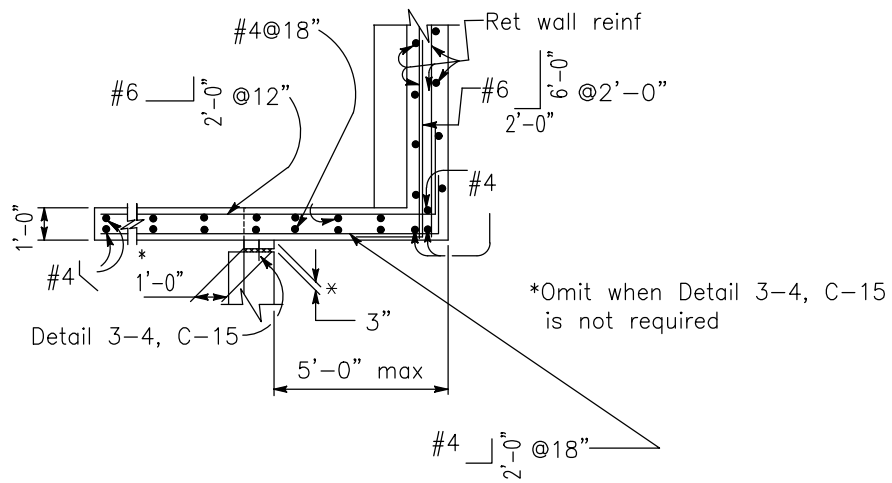

PLAN

(For return wall type "B")

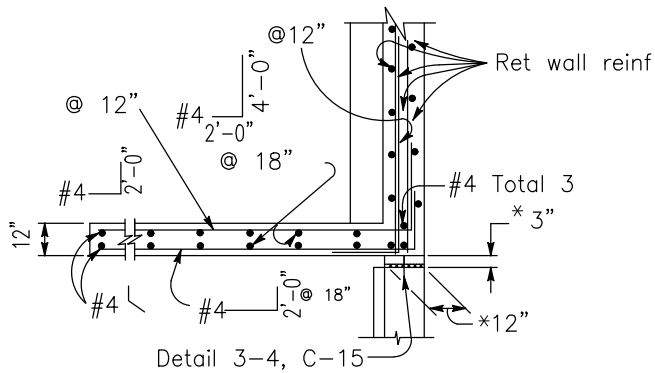

PLAN

(For return wall type "C")

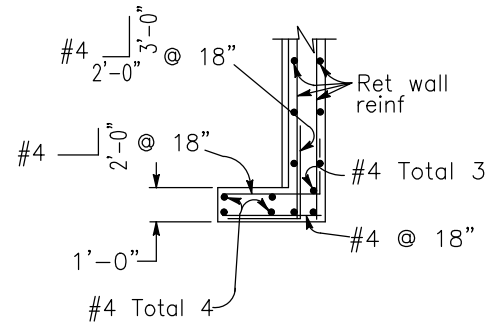

PLAN

(For return wall type "D")

Revision	By	Approved	Date
ORIGINAL		Kercheval	12/75
Reviewed	TS	T. Stanton	11/15
Reviewed	DH	T. Stanton	09/18
Reviewed	RP	S. Engeda	03/22

SAN DIEGO REGIONAL STANDARD DRAWING

**REINFORCED CONCRETE
RETAINING WALL DETAILS No. 1**

RECOMMENDED BY THE SAN DIEGO REGIONAL STANDARDS COMMITTEE

Samantha Engeda 03/24/2022
Chairperson R.C.E. 52241 Date

DRAWING NUMBER **C-13B**

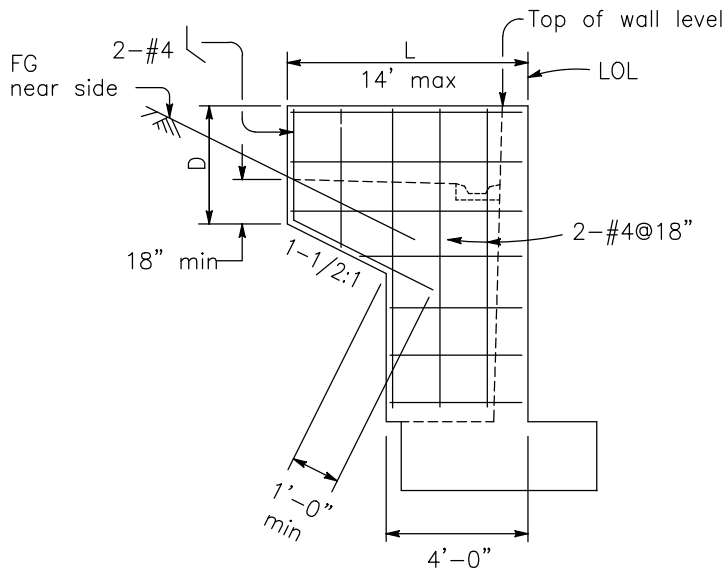

ELEVATION

RETURN WALL TYPE A

Use where H=8' or less

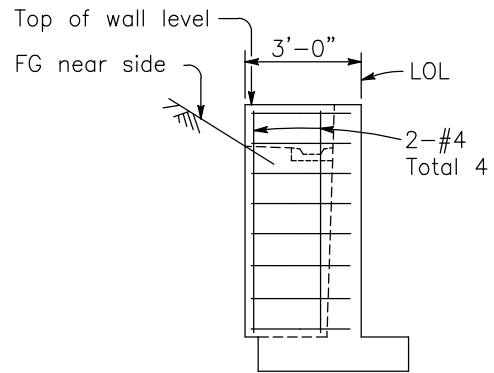

ELEVATION

RETURN WALL TYPE D

Use where H=6' or less

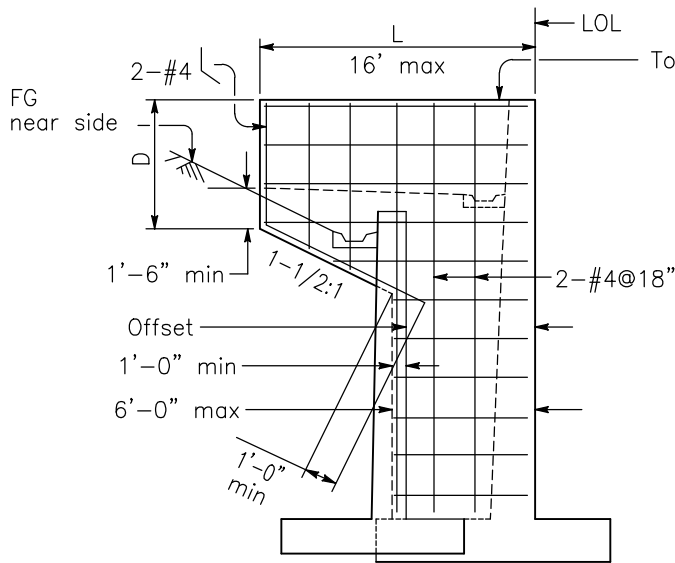

ELEVATION

RETURN WALL TYPE B

Use where H=10' or more on offset walls

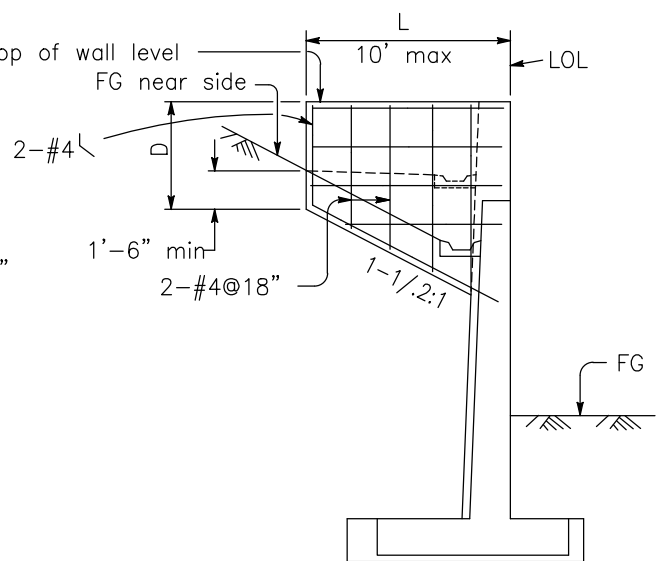

ELEVATION

RETURN WALL TYPE C

Use where H=10' or more on straight walls

Revision	By	Approved	Date
ORIGINAL		Kercheval	12/75
Delete	Metric	S.S. T. Shell	03/11
Reviewed	TS	T. Stanton	11/15
Reviewed	RP	S. Engeda	03/22

SAN DIEGO REGIONAL STANDARD DRAWING

**REINFORCED CONCRETE
RETAINING WALL DETAILS No. 1**

RECOMMENDED BY THE SAN DIEGO REGIONAL STANDARDS COMMITTEE

Saman Engeda 03/24/2022
Chairperson R.C.E. 52241 Date

DRAWING NUMBER **C-13C**

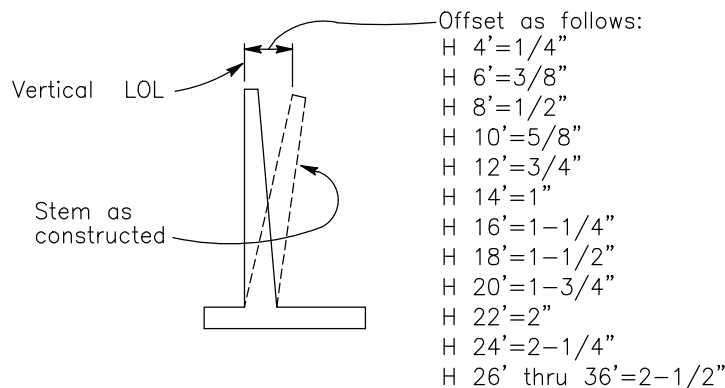
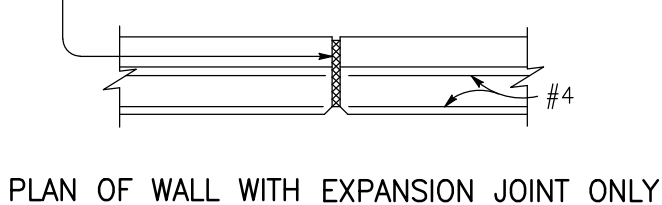
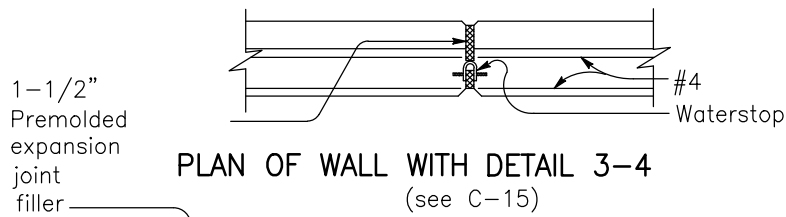

APPROX. WALL OFFSET VALUES

Not required for wall Types 3 and 4.
Values for offsetting forms to be determined by the Engineer.

NOTES

Design Conditions:

Design H may be exceeded by 6" before going to the next size. Special footing design is required where foundation material is incapable of supporting toe pressure listed in table. Return wall not required unless shown elsewhere.

Design Data:

$f_c = 1300$ psi $f'_c = 3250$ psi $f_s = 24,000$ psi
 $n = 10$ earth = 120 pcf
 2' Surcharge:

Equivalent fluid pressure =

36 pcf maximum for determination of toe pressure.
 27 pcf minimum for determination of heel pressure.

Earth pressures for 2:1 unlimited slope, 1-1/2:1 slope, and 1-1/2:1 unlimited slope, determined from Rankine's formula with $\phi = 33^\circ - 42^\circ$.

Revision	By	Approved	Date	SAN DIEGO REGIONAL STANDARD DRAWING		RECOMMENDED BY THE SAN DIEGO REGIONAL STANDARDS COMMITTEE	
ORIGINAL		Kercheval	12/75	REINFORCED CONCRETE RETAINING WALL DETAILS No. 1		<i>Saman Engeda</i> 03/24/2022	
Delete Metric	S.S.	T. Shell	03/11			Chairperson R.C.E. 52241	Date
Reviewed	TS	T. Stanton	11/15				
Reviewed	RP	S. Engeda	03/22				
				DRAWING NUMBER		C-13D	

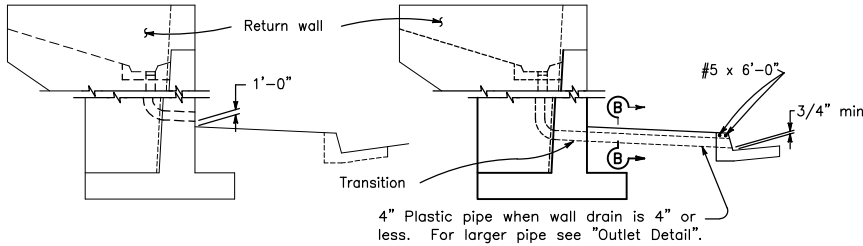

**RETAINING WALL,
FACE OF WALL OUTLET**

RETAINING WALL, GUTTER OUTLET

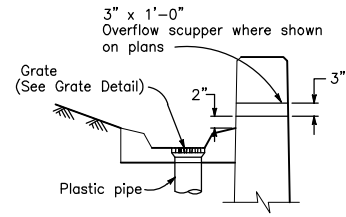

WALL DRAIN DETAIL

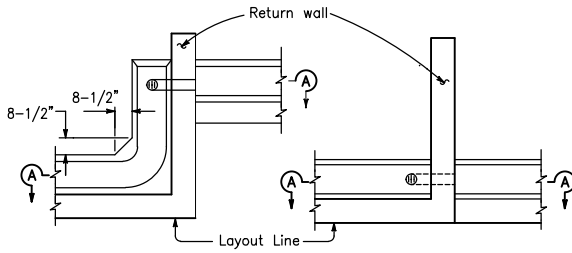

**PLAN-OFFSET WALL
PLAN-CONTINUOUS WALL
DRAIN THROUGH RETURN WALL**

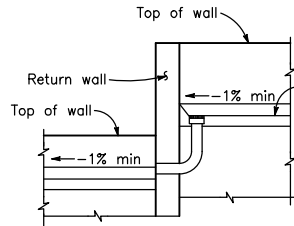

SECTION A-A

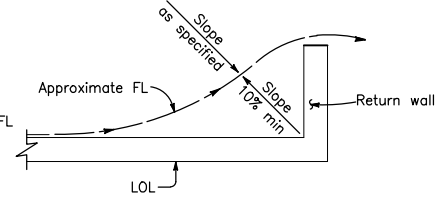

**WALL DRAINAGE
WHERE GUTTER NOT REQUIRED**

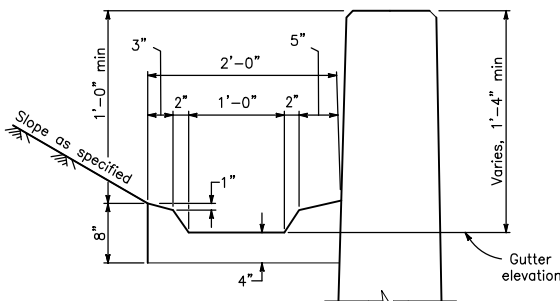

TYPICAL GUTTER DETAIL

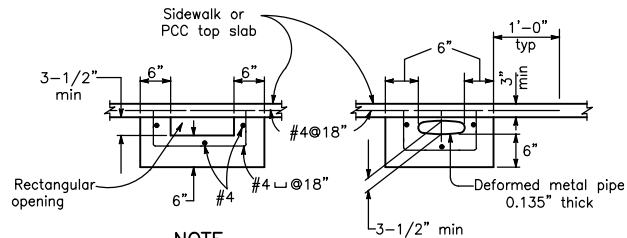

NOTE

Area of opening to be not less than that of pipe from wall gutter. Make opening transition in wall. Edge opening in curb face to 3/4" minimum radius.

OUTLET DETAIL - SECTION B-B



GRATE DETAIL

Sizes to fit standard hubs

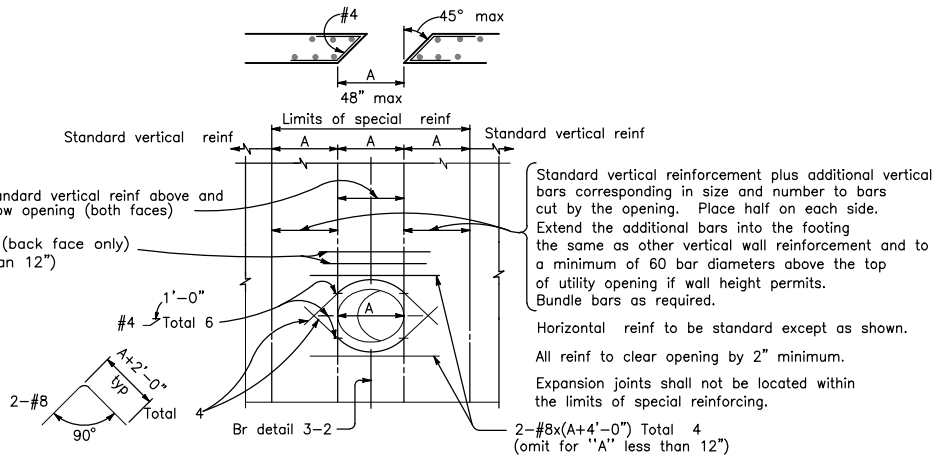

RETAINING WALL UTILITY OPENING

Max size of opening (A) = 48" to be used in conjunction with C-13

Revision	By	Approved	Date
ORIGINAL		Kercheval	12/75
Delete	Metric S.S.	T. Shell	03/11
Reviewed	TS	T. Stanton	11/15
Reviewed	RP	S. Engeda	03/22

SAN DIEGO REGIONAL STANDARD DRAWING

**REINFORCED CONCRETE
RETAINING WALL DETAILS No. 2**

RECOMMENDED BY THE SAN DIEGO REGIONAL STANDARDS COMMITTEE

Saman Engeda 03/24/2022
Chairperson R.C.E. 52241 Date

**DRAWING
NUMBER C-14**

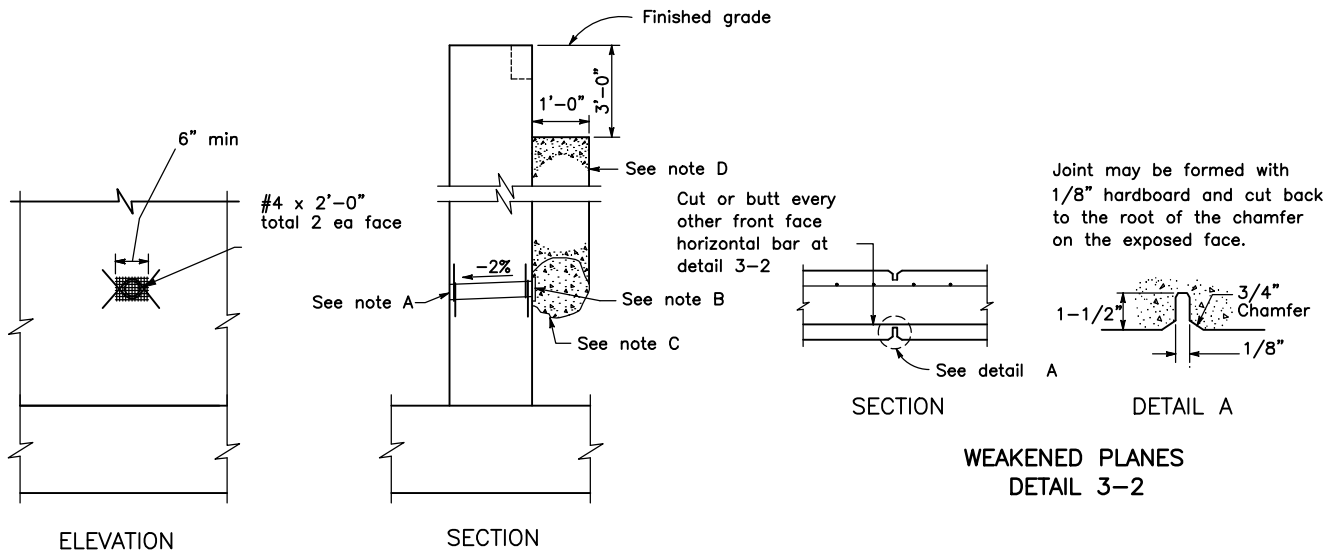

**WEEP HOLE AND PERVIOUS BACKFILL
DETAIL 3-1**

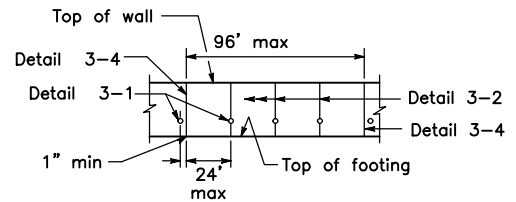

**WALL EXPANSION JOINTS
AND WEAKENED PLANES
DETAIL 3-3**

NOTES

- A. 4" diameter drain @ 25' max center to center (9' c-c for Type 3 and 9'-3" c-c for Type 4 Retaining Walls). For walls adjacent to sidewalks or curbs, provide 4" cast iron or asbestos cement pipe under the sidewalk to discharge thru curb face. Exposed wall drains shall be located 3" ± above finished grade.
- B. 6" square aluminum or galvanized steel wire 4 mesh hardware cloth. (Min wire diameter 0.03") Anchor firmly to backface.
- C. One cubic foot pervious backfill material in a burlap sack, securely tied.
- D. Pervious backfill material continuous behind retaining wall.

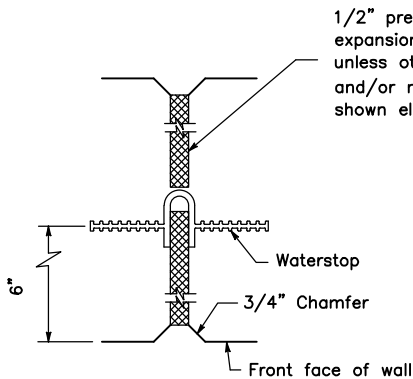

**WALL EXPANSION JOINT
DETAIL 3-4**

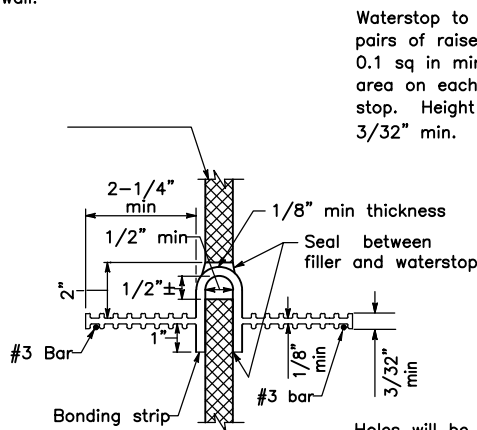

**WATERSTOP
DETAIL 3-6**

Waterstop to have 5 or more pairs of raised ribs to provide 0.1 sq in min rib cross-section area on each half of the water stop. Height of ribs to be 3/32" min.

Holes will be permitted in the outer 1/2" of the web for wire, rings etc. Tie web to #3 reinforcing bars @ 12" max intervals to support the waterstop in proper position during concrete placement. Alternative detail may be submitted for approval of the engineer.

Revision	By	Approved	Date
ORIGINAL		Kercheval	12/75
Delete Metric	S.S.	T. Shell	03/11
Reviewed	TS	T. Stanton	11/15
Reviewed	RP	S. Engeda	03/22

SAN DIEGO REGIONAL STANDARD DRAWING

**REINFORCED CONCRETE
RETAINING WALL DETAILS No. 3**

RECOMMENDED BY THE SAN DIEGO REGIONAL STANDARDS COMMITTEE

Saman Engeda 03/24/2022
Chairperson R.C.E. 52241 Date

DRAWING NUMBER **C-15**